

# Transistors

## 2SC9014

### PRE-AMPLIFIER, LOW LEVEL & LOW NOISE

- High total power dissipation. (PT=450mW)
- High  $h_{FE}$  and good linearity
- Complementary to SS9015

### ABSOLUTE MAXIMUM RATINGS ( $T_a = 25^\circ\text{C}$ )

Characteristic	Symbol	Rating	Unit
Collector-Base Voltage	$V_{CB0}$	50	V
Collector-Emitter Voltage	$V_{CEO}$	45	V
Emitter-Base Voltage	$V_{EBO}$	5	V
Collector Current	$I_C$	100	mA
Collector Dissipation	$P_C$	450	mW
Junction Temperature	$T_j$	150	$^\circ\text{C}$
Storage Temperature	$T_{stg}$	-55~150	$^\circ\text{C}$

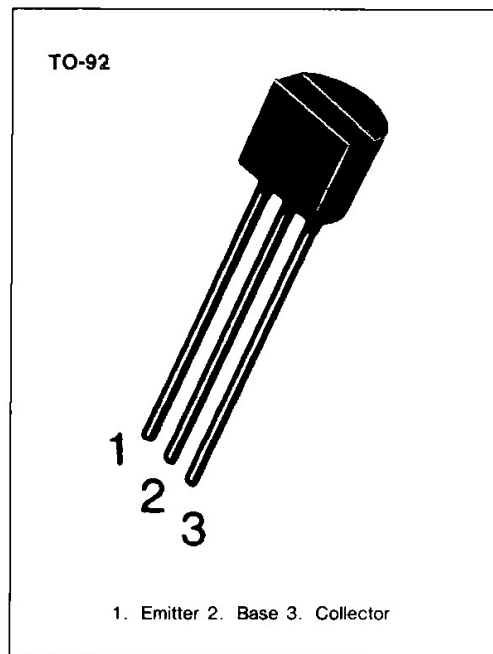

### ELECTRICAL CHARACTERISTICS ( $T_a = 25^\circ\text{C}$ )

Characteristic	Symbol	Test Conditions	Min	Typ	Max	Unit
Collector-Base Breakdown Voltage	$BV_{CB0}$	$I_C = 100\mu\text{A}, I_E = 0$	50			V
Collector-Emitter Breakdown Voltage	$BV_{CEO}$	$I_C = 1\text{mA}, I_B = 0$	45			V
Emitter-Base Breakdown Voltage	$BV_{EBO}$	$I_E = 100\mu\text{A}, I_C = 0$	5			V
Collector Cutoff Current	$I_{CB0}$	$V_{CB} = 50\text{V}, I_E = 0$			50	nA
Emitter Cutoff Current	$I_{EBO}$	$V_{EB} = 5\text{V}, I_C = 0$			50	nA
DC Current Gain	$h_{FE}$	$V_{CE} = 5\text{V}, I_C = 1\text{mA}$	60	280	1000	
Collector-Base Saturation Voltage	$V_{CE(sat)}$	$I_C = 100\text{mA}, I_B = 5\text{mA}$		0.14	0.3	V
Base-Emitter Saturation Voltage	$V_{BE(sat)}$	$I_C = 100\text{mA}, I_B = 5\text{mA}$		0.84	1.0	V
Base-Emitter On Voltage	$V_{BE(on)}$	$V_{CE} = 5\text{V}, I_C = 2\text{mA}$	0.58	0.63	0.7	V
Output Capacitance	$C_{ob}$	$V_{CB} = 10\text{V}, I_E = 0$ $f = 1\text{MHz}$		2.2	3.5	pF
Current Gain-Bandwidth Product	$f_T$	$V_{CE} = 5\text{V}, I_C = 10\text{mA}$	150	270		MHz
Noise Figure	NF	$V_{CE} = 5\text{V}, I_C = 0.2\text{mA}$ $f = 1\text{KHz}, R_s = 2\text{K}\Omega$		0.9	10	dB

### $h_{FE}$ CLASSIFICATION

Classification	A	B	C	D
$h_{FE}$	60-150	100-300	200-600	400-1000



**STATIC CHARACTERISTIC**

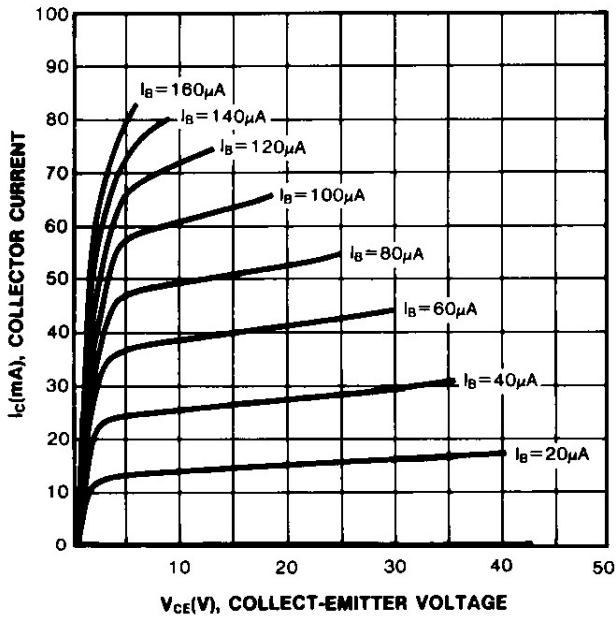

**DC CURRENT GAIN**

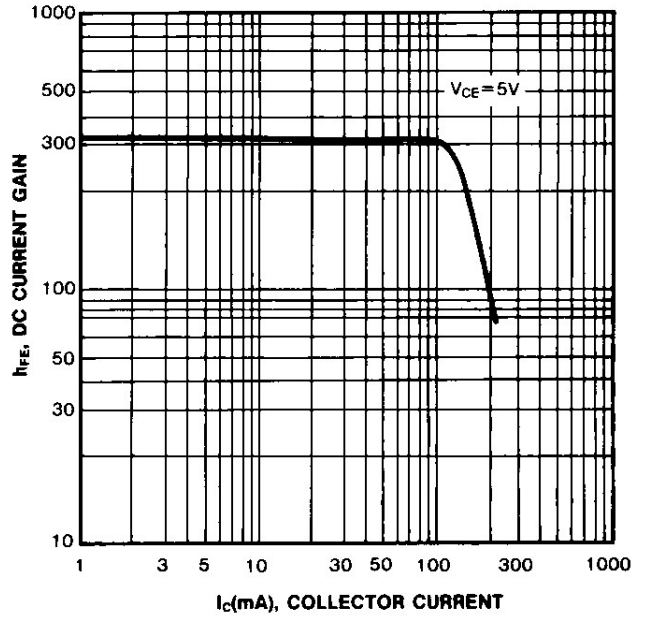

**BASE-EMITTER SATURATION VOLTAGE  
COLLECTOR-EMITTER SATURATION VOLTAGE**

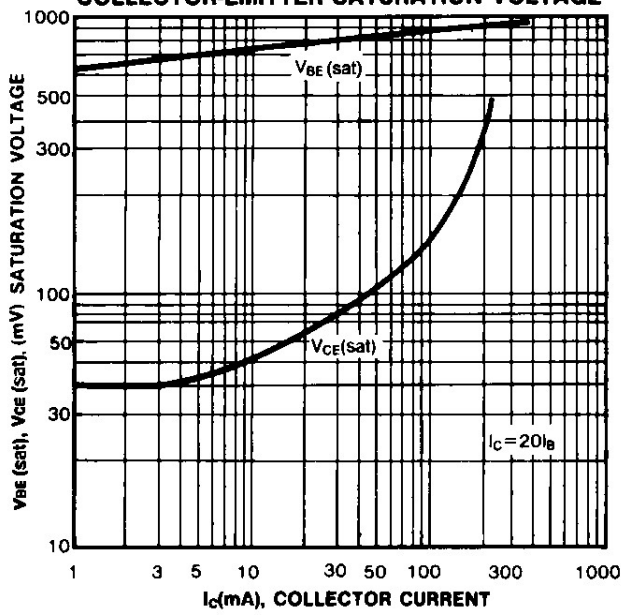

**CURRENT GAIN-BANDWIDTH PRODUCT**

