

# AN1431T, AN1431M

## Surface-mount Adjustable Output Shunt Regulator

### Overview

The AN1431T and AN1431M are high accuracy stabilized power supplies in which the output voltage can be adjusted in the range from approx. 2.5 to 36V by using the external resistor under the operating temperature. Because of its fast rise characteristics, it can be replaced with Zener diode and has the wide application range.

### Features

- High precision reference voltage :  $2.5V \pm 2\%$
- High-temperature stability :  $17\text{ppm}/^\circ\text{C}$  typ.
- Output voltage externally adjustable : 2.5 to 36V
- Fast rise
- Low input impedance :  $0.2\Omega$  (typ.)
- Low output noise voltage

### Pin Name

<AN1431T>

Pin No.	Pin name
1	Cathode
2	Reference pin
3	Anode

<AN1431M>

Pin No.	Pin name
1	Reference pin
2	Anode
3	Cathode

### Block Diagram

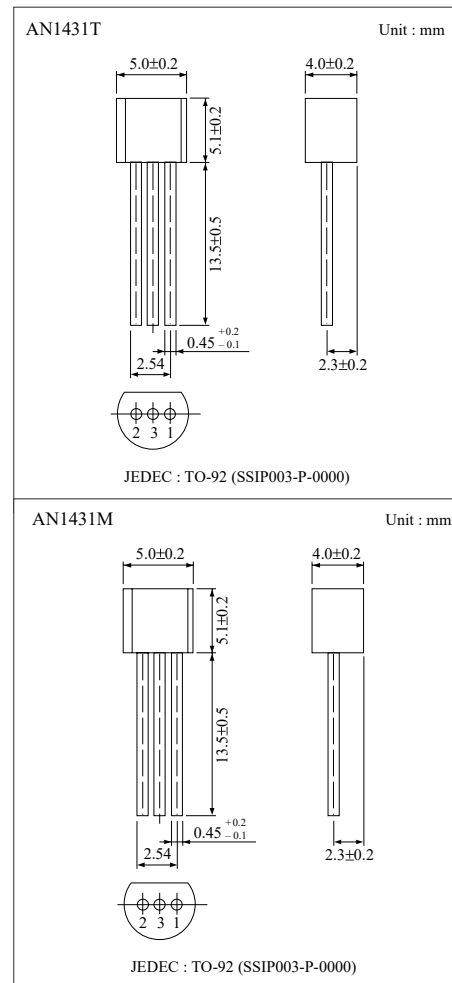
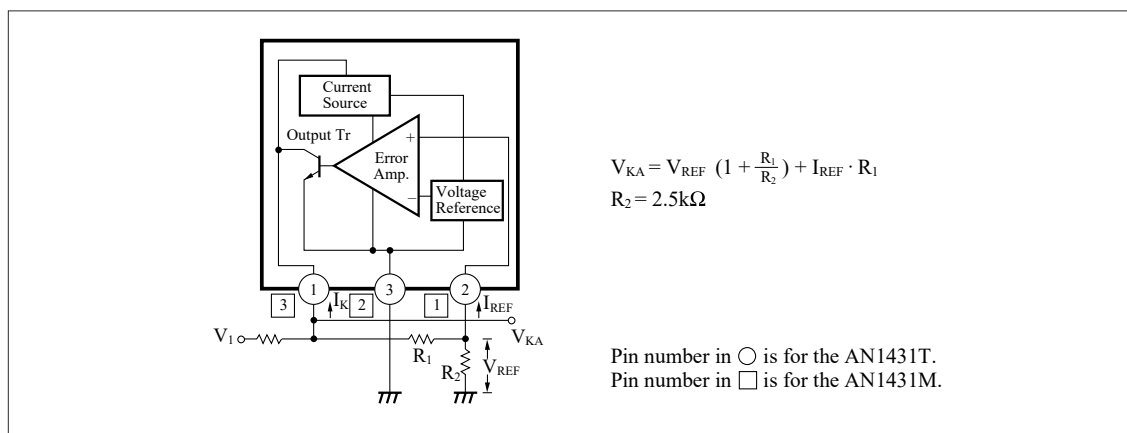

## ■ Absolute Maximum Ratings (Ta=25°C)

Parameter	Symbol	Rating	Unit
Supply voltage	V <sub>CC</sub>	37	V
Supply current	I <sub>CC</sub>	-100 to+150	mA
Power dissipation	P <sub>D</sub>	650 *	mW
Reference input current	I <sub>REF</sub>	-0.05 to+10	mA
Operating ambient temperature	AN1431T	V <sub>opr</sub>	°C
	AN1431M		
Storage temperature	AN1431T	T <sub>stg</sub>	°C
	AN1431M		

\* For the AN1431M, SM to the printed board (glass epoxy of 20 × 20 × 1.7mm with copper film of 1cm<sup>2</sup>)

## ■ Recommended Operating Range (Ta=25°C)

Parameter	Symbol	Range
Operating supply voltage range	V <sub>KA</sub>	V <sub>REF</sub> (2.5 to 36V)

## ■ Electrical Characteristics (Ta=25°C)

Parameter	Symbol	Condition	min	typ	max	Unit
Reference voltage	V <sub>REF</sub>	V <sub>KA</sub> =V <sub>REF</sub> , I <sub>K</sub> =10mA	2.45	2.50	2.55	V
Reference voltage temperature deviation	V <sub>REF (Jev)</sub> *1 *2	V <sub>KA</sub> =V <sub>REF</sub> , I <sub>K</sub> =10mA, Ta=0 to+70°C	—	3	17	mV
Reference voltage fluctuation	ΔV <sub>REF</sub>	I <sub>K</sub> =10mA, DV <sub>KA</sub> =10V to V <sub>REF</sub>	—	-1.2	-2.7	mV/V
	ΔV <sub>KA</sub>	I <sub>K</sub> =10mA, DV <sub>KA</sub> =36 to 10V	—	-1	-2	mV/V
Reference input current	I <sub>REF</sub>	I <sub>K</sub> =10mA, R <sub>1</sub> =10kΩ, R <sub>2</sub> =∞	—	2	4	μA
Reference input current temperature deviation	I <sub>REF (Jev)</sub> *2	I <sub>K</sub> =10mA, R <sub>1</sub> =10kΩ, R <sub>2</sub> =∞, Ta=0 to+70°C	—	0.4	1.2	μA
Minimum cathode current	I <sub>min</sub>	V <sub>KA</sub> =V <sub>REF</sub>	—	0.4	1.0	mA
Off-state cathode current	I <sub>OFF</sub>	V <sub>KA</sub> =36V, V <sub>REF</sub> =0V	—	0.1	1.0	μA
Dynamic impedance	Z <sub>KA</sub>   *3	V <sub>KA</sub> =V <sub>REF</sub> , I <sub>K</sub> =1 to 100mA, f ≤ 1kHz	—	0.2	0.5	Ω

\*1

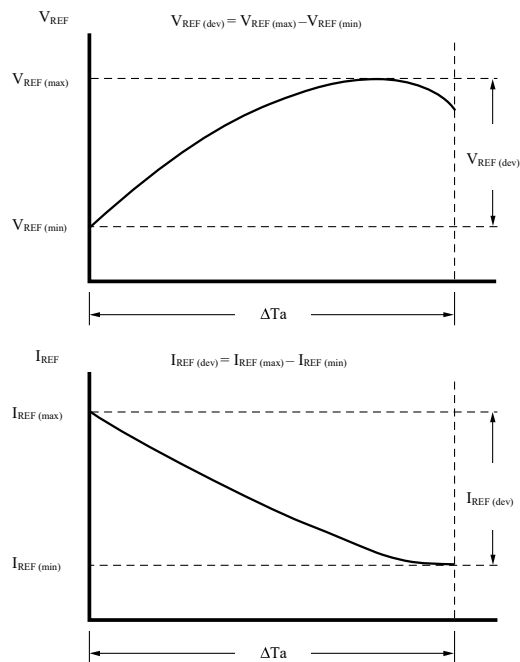

The temperature coefficient  $aV_{REF}$  for the reference input voltage is equivalently given by the following expression.

$$|aV_{REF}| = \frac{V_{REF(dev)}}{\frac{V_{REF}^*}{\Delta T_a}} \times 10^6 \text{ (ppm/}^\circ\text{C)}$$

\* $V_{REF}$  at  $T_a = 25^\circ\text{C}$

For example, assuming the following ;

$$V_{REF(max)} = 2500\text{mV (} T_a = 30^\circ\text{C),}$$

$$V_{REF(min)} = 2497\text{mV (} T_a = 0^\circ\text{C),}$$

$$(V_{REF(dev)} = 3\text{mV),}$$

$$V_{REF} = 2499\text{mV (} T_a = 25^\circ\text{C)}$$

$$\Delta T_a = 70^\circ\text{C}$$

Then, the following expression is established.

$$|aV_{REF}| = \frac{3\text{mV}}{\frac{2499\text{mV}}{70^\circ\text{C}}} \times 10^6 = 17.1 \text{ (ppm/}^\circ\text{C)}$$

\*2 These values are design reference values, not guaranteed ones.

\*3 The dynamic impedance is defined by the following expression.

$$|Z_{KA}| = \frac{\Delta V_{KA}}{\Delta I_K}$$

The total dynamic impedance at  $\Delta V_{REF}$ ,  $\Delta V_{KA}$ ,  $I_{REF}$ , and  $I_{REF(dev)}$  is as follows.

$$|Z| = \frac{\Delta V}{\Delta I} = |Z_{KA}| \left( 1 + \frac{R_1}{R_2} \right)$$

## ■ Power Dissipation

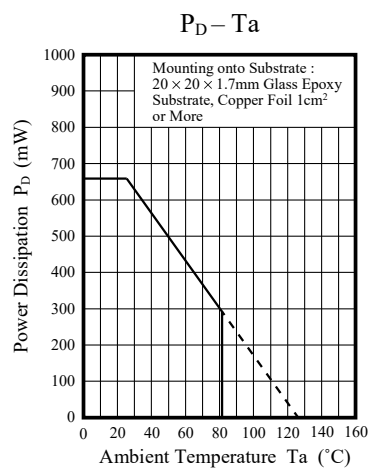

## Application Circuits

1. Shunt Regulator

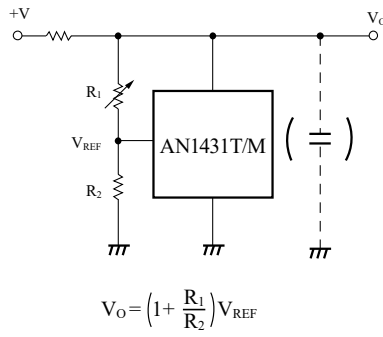

2. Constant Current Power Supply

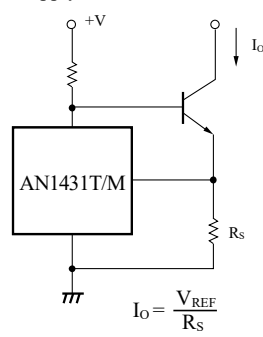

3. Constant Current Source

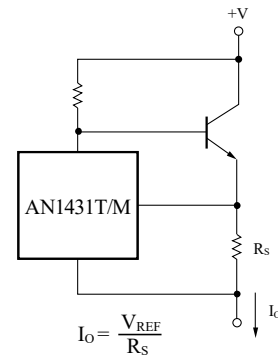

4. Current Boost

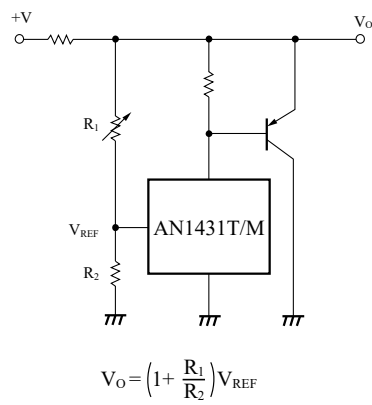

5. Adjustable Output Regulator Combined with 3-pin Regulator

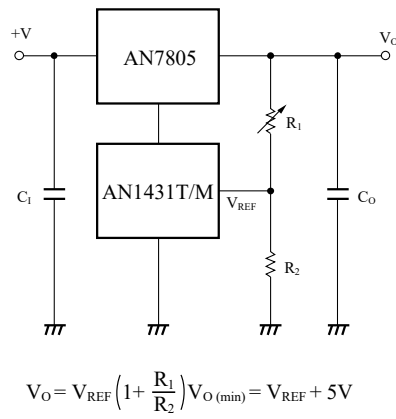

## Characteristics Curve

