

STEREO AUDIO AMPLIFIER

DESCRIPTION

The AV2025 is a monolithic integrated circuit consisting of a 2 channel power amplifier. It is suitable for stereo and bridge amplifier application of radio cassette tape recorders.

FEATURES

- Bridge or stereo configuration.
- Few External components
- High Channel isolation
- Voltage range : 3V to 12V
- Power on/off no noise
- Voltage gain up to 45dB(Adjustable with external resistor)
- Soft clipping
- Internal Thermal protection
- Working Voltage down to 3V

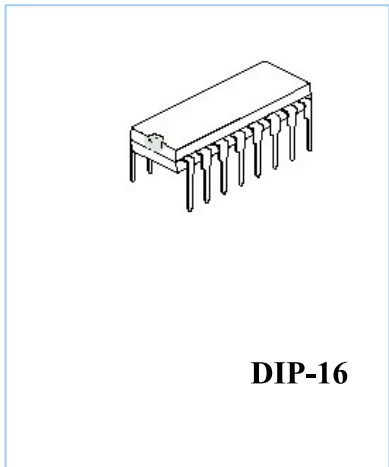

BLOCK DIAGRAM

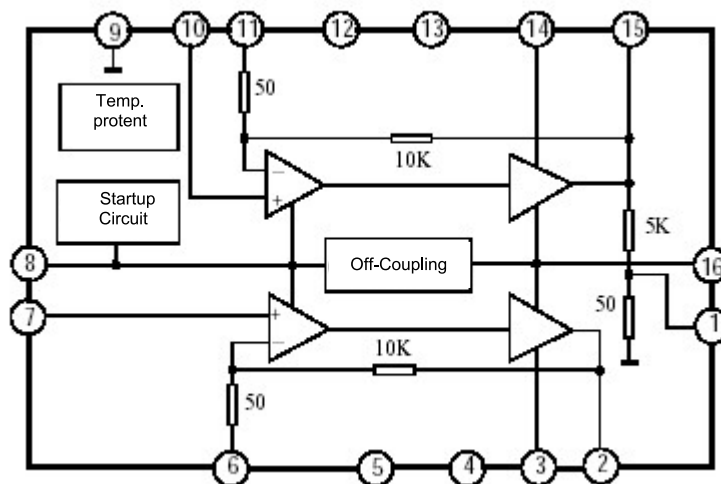

PIN CONFIGURATION

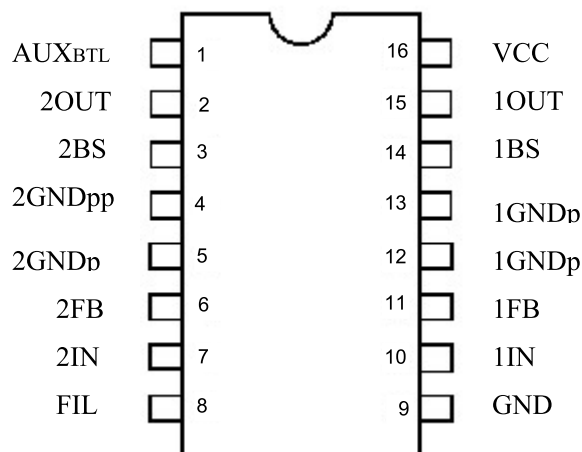

ORDERING INFORMATION

PIN	SYMBOL	PIN	SYMBOL
1	AUX _{BTL}	9	GND
2	2OUT	10	1IN
3	2BS	11	1FB
4	2GND _p	12	1GND _p
5	2GND _p	13	1GND _p
6	2FB	14	1BS
7	2IN	15	1OUT
8	FIL	16	VCC

ABSOLUTE MAXIMUM RATINGS (T_{amb}=25°C)

PARAMETER	SYMBOL	VALUE	UNIT
Supply	V _{cc}	15	V
Output Peak Current	I _{op}	1.5	A
Junction Temperature	T _j	150°C	°C
Storage Temperature	T _s	-40°C ~+150°C	°C

ELECTRICAL CHARACTERISTICS(T_A=+25°C, V_{cc}=9V, f=1KHz, R_L=8Ω, unless otherwise specified).

PARAMETER	SYMBOL	TEST CONDITIONS		MIN	TYP	MAX	UNIT
Supply Voltage	V _{cc}			3	-	12	V
Quiescent Current	I _{cc}	V _i =0, Stereo		-	40	50	mA
Quiescent Output Voltage	V _o (DC)			4.0	4.5	5.0	V
Closed Loop Voltage Gain	A _v	Stereo	V _i =-45dBm	43	45	47	dB
		Bridge		49	51	53	
Channel Balance	CB	Stereo		-1	0	+1	dB
Total Harmonic Distortion	THD	Stereo	P _o =250mW, f=1kHz, R _L =4Ω, V _{cc} =9V	-	0.3	1.5	%
		Bridge		-	0.5	-	

PARAMETER	SYMBOL	TEST CONDITIONS	MIN	TYP	MAX	UNIT		
Input Resistance	Zi			30		KΩ		
Channel Separation	CSR	Rg=10KΩ, f=1kHz, RL=4Ω, Po=1W	40	55	-	dB		
Ripple Rejection	Srip	Rg=0, frip=100Hz, Vrip=150mV, Av=45dB	40	46	-	dB		
Input Noise Voltage	VNI	BW:20Hz-20kHz, Av=200	Rg=0Ω	-	1.5	3	uV	
			Rg=10KΩ	-	3	6		
Output Power	Po	THD=10%, f=1kHz	Stereo	Vcc=9V, RL=4Ω	1.7	2.3	-	W
				Vcc=6V, RL=8Ω	-	1.3	-	
				Vcc=6V, RL=4Ω	0.7	1.0	-	
			Bridge	Vcc=6V, RL=8Ω	-	0.6	-	
				Vcc=3V, RL=4Ω	-	0.1	-	
				Vcc=9V, RL=8Ω	-	4.7	-	
			Vcc=6V, RL=4Ω	-	2.8	-		

APPLICATION CIRCUIT

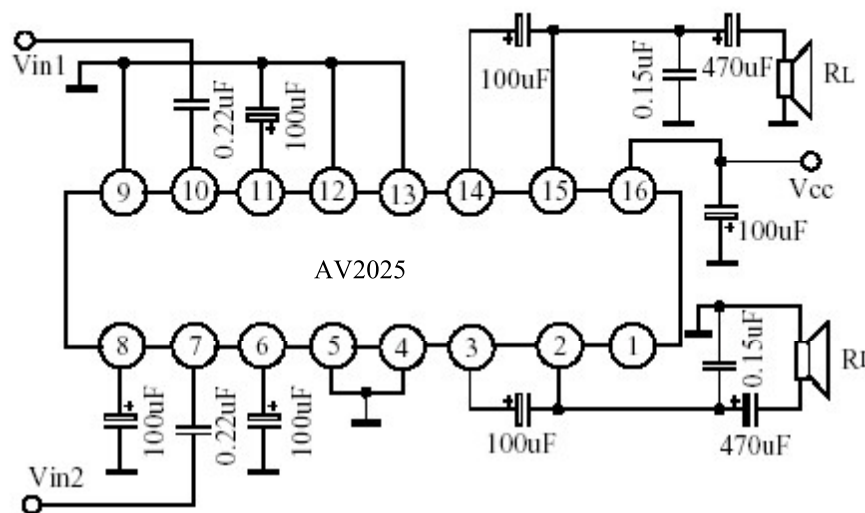

(1.STEREO)

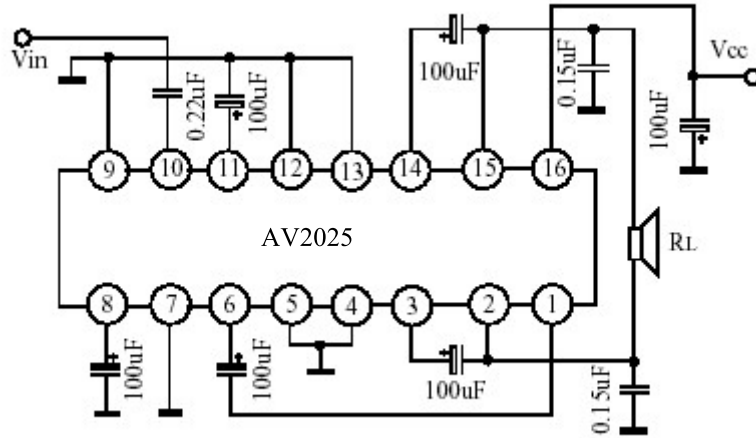

(2.BRIDGE)

TYPICAL PERFORMANCE CHARACTERISTICS

