

## ADJUSTABLE PRECISION SHUNT REGULATOR

### ❖ GENERAL DESCRIPTION

The AX431/A is a low voltage three terminal adjustable shunt regulator with a guaranteed thermal stability over applicable temperature ranges. The output voltage can be set to any value between 2.495V (VREF) to 36V with two external resistors (see application circuit). The high precise Reference voltage tolerance is  $\pm 1\%$  by AX431 and  $\pm 0.5\%$  by AX431A. This device has a typical output impedance of  $0.2\Omega$ . Active output circuitry provides a very sharp turn on characteristic, making this device excel lent replacement for Zener diodes in many applications.

The AX431/A is characterized for operation from  $-20^{\circ}\text{C}$  to  $85^{\circ}\text{C}$ . The AX431/A is two types (R and W types) available in a low profile SOT23-3L and SOT-23-5L packages.

### ❖ FEATURES

- Precision reference voltage  
     AX431:  $2.495\text{V} \pm 1\%$   
     AX431A:  $2.495\text{V} \pm 0.5\%$
- Adjustable output voltage is VREF to 36V
- Sink current capability is 200mA
- Low dynamic output impedance is  $0.2\Omega$  (typ.)
- Minimum Cathode current for regulation is 0.2mA (typ.)
- SOT-23-3L and SOT-23-5L Pb-Free packages

### ❖ PIN ASSIGNMET

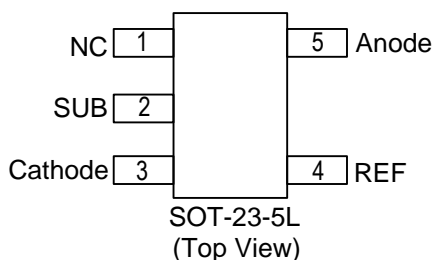
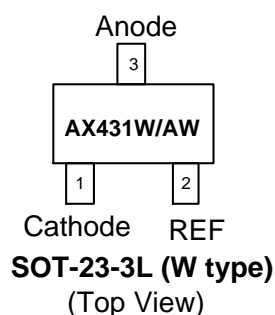
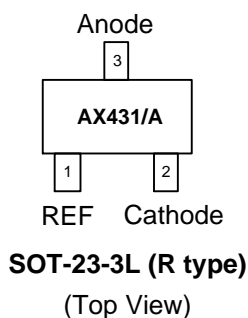

note: The Pin2 is SUB, so connect the terminal to GND.

❖ BLOCK DIAGRAM

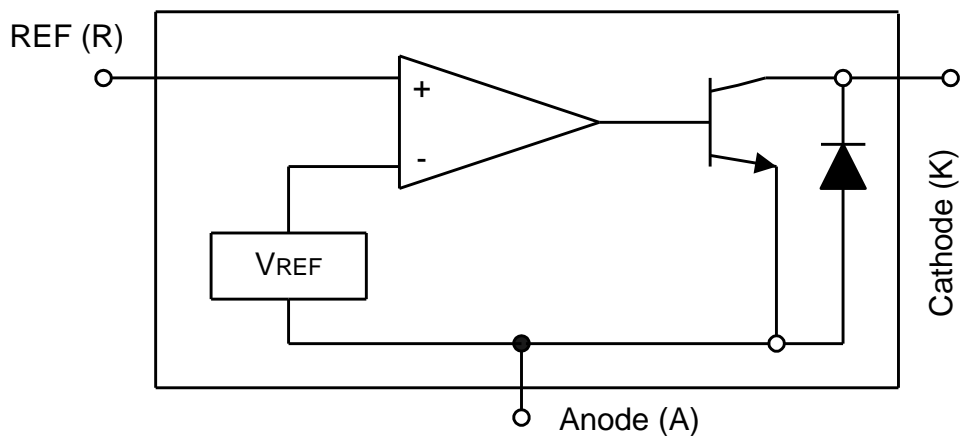

❖ SYMBOL

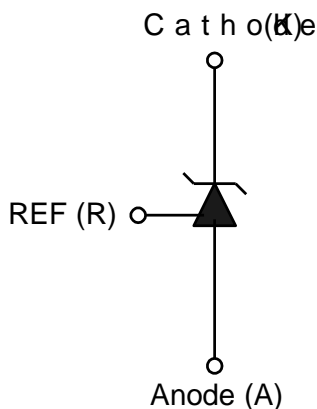

❖ ORDER/MARKING INFORMATION

Order Information	Top Marking
<p style="text-align: center;"><b>AX431 X X X X</b></p> <p>Ref Voltage Tolerance: Blank : ±1% A : ±0.5%</p> <p>Pin Type: Blank: R type W: W type</p> <p>Package Type: R: SOT-23-3L B: SOT-23-5L</p> <p>Packing: Blank : Bag A : Taping</p>	<p style="text-align: center;"><b>L L Y W X</b></p> <p>→ ID code: internal</p> <p>→ WW: 01~26(A~Z) 27~52(a~z)</p> <p>→ Year: A=2010 1=2011</p> <p>R1: AX431 R2: AX431A RA: AX431W RB: AX431AW</p>

❖ **ABSOLUTE MAXIMUM RATINGS** (at  $T_A=25^{\circ}\text{C}$ )

Characteristics	Symbol	Rating	Unit
Cathode Voltage	$V_{KA}$	36	V
Continuous Cathode Current	$I_{KA}$	250	mA
Reference Input Current	$I_{REF}$	10	mA
Operating Temperature	$T_{OP}$	-20~105	$^{\circ}\text{C}$
Junction Temperature	$T_J$	-40~125	$^{\circ}\text{C}$
Storage Temperature	$T_{STG}$	-40~150	$^{\circ}\text{C}$
Thermal Resistance from Junction to ambient	$\theta_{JA}$	156	$^{\circ}\text{C}/\text{W}$
Power Dissipation[ $PD=(T_J-T_A) / \theta_{JA}$ ]	PD	0.25	W

Note :  $\theta_{JA}$  is measured with the PCB copper area of approximately 1 in<sup>2</sup>(Multi-layer).

❖ **ELECTRICAL CHARACTERISTICS** ( $T_A=25^{\circ}\text{C}$ , unless otherwise specified)

Characteristics	Symbol	Conditions	Min	Typ	Max	Units	
Reference Voltage	$V_{REF}$	$V_{KA} = V_{REF}$ , $I_{KA} = 10\text{mA}$ (Fig.1)	AX431	2.470	2.495	2.520	V
			AX431A	2.482	-	2.507	
Deviation of Reference Input Voltage over full temperature range	$V_{REF(DEV)}$	$V_{KA} = V_{REF}$ , $I_{KA} = 10\text{mA}$ , $T_A = -20\sim 85^{\circ}\text{C}$ (Fig.1)		6	20	mV	
Reference Input Current	$I_{REF}$	$R1 = 10\text{K}\Omega$ , $R2 = \infty$ $I_{KA} = 10\text{mA}$ (Fig.2)	-	1.5	3.5	$\mu\text{A}$	
Deviation of Reference Input Current over Temperature	$I_{REF(DEV)}$	$R1 = 10\text{K}\Omega$ , $R2 = \infty$ $I_{KA} = 10\text{mA}$ $T_A = -20\sim 85^{\circ}\text{C}$ (Fig.2)	-	0.4	1.2	$\mu\text{A}$	
Ratio of the Change in Reference Voltage to the Change in Cathode Voltage	$\frac{\Delta V_{REF}}{\Delta V_{KA}}$	$I_{KA} = 10\text{mA}$ (Fig.2)	$V_{KA}=10\text{V} \sim V_{REF}$	-	-1.2	-2.0	mV/V
			$V_{KA}=36\text{V} \sim 10\text{V}$	-	-1	-2.0	
Minimum Cathode Current for Regulation	$I_{KA(min)}$	$V_{KA} = V_{REF}$ (Fig.1)	-	0.2	0.5	mA	
Off-state Cathode Current	$I_{KA(OFF)}$	$V_{KA} = 36\text{V}$ , $V_{REF} = 0\text{V}$ (Fig.3)	-	0.1	1	$\mu\text{A}$	
Dynamic Output Impedance	$ Z_{KA} $	$V_{KA} = V_{REF}$ Frequency $\leq 1\text{KHz}$ (Fig.1)	-	0.2	0.5	$\Omega$	

❖ APPLICATION CIRCUIT

Fig1:  $V_{KA}=V_{REF}$

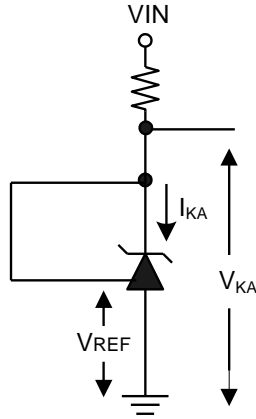
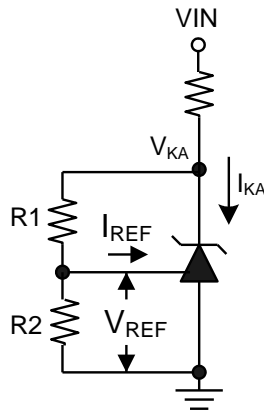
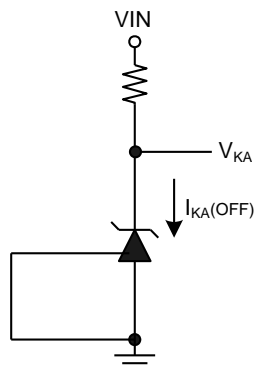

Fig2:  $V_{KA}>V_{REF}$



$$V_{KA} = V_{REF}(1 + R1/R2) + I_{REF} * R1$$

Fig3: Off state current



❖ **TYPICAL CHARACTERISTICS**

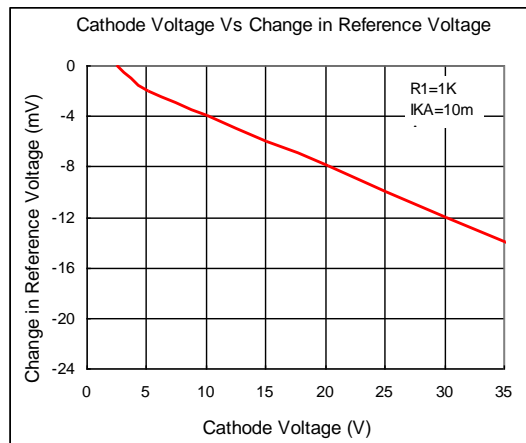
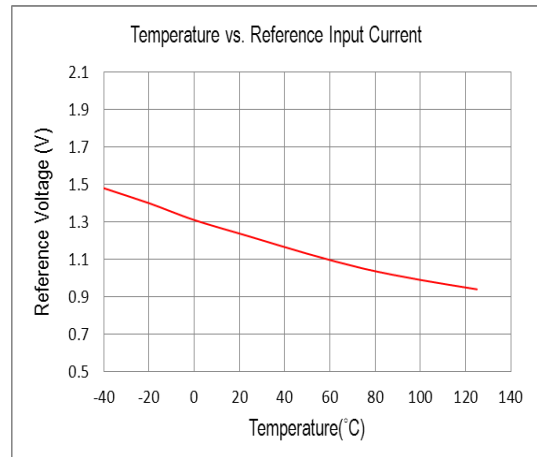
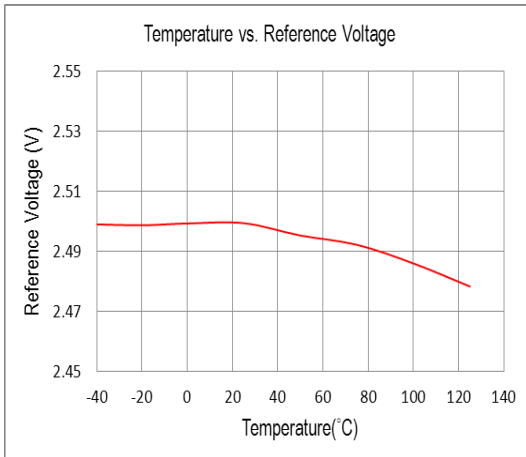
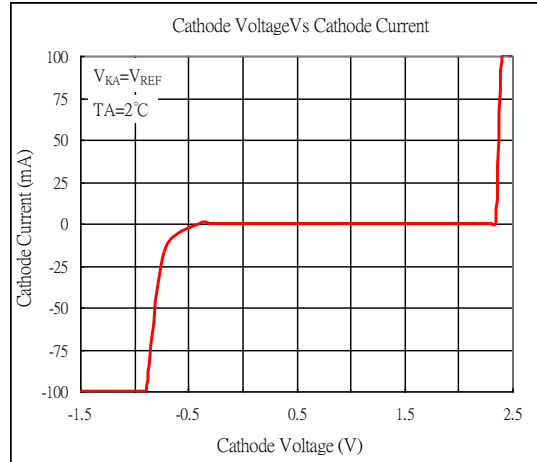
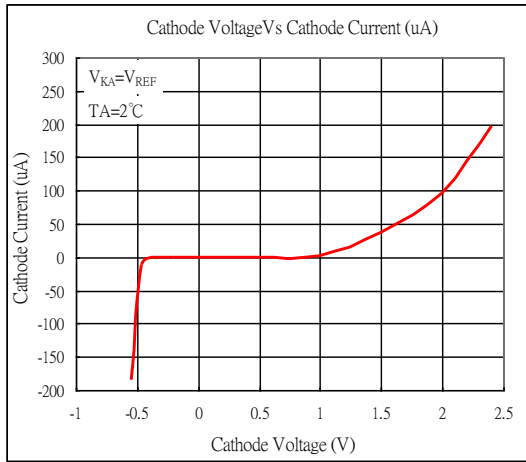

❖ **TYPICAL CHARACTERISTICS (CONTINUED)**

(1) Small Signal Voltage Amplification vs. Frequency

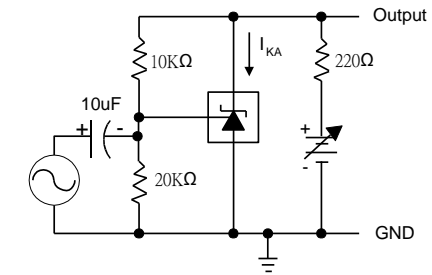
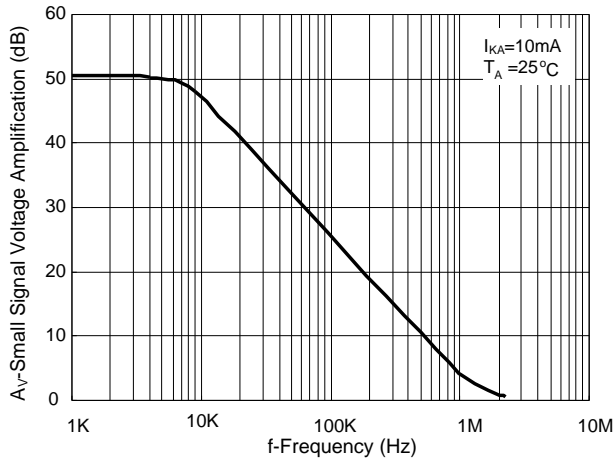

TEST CIRCUIT FOR VOLTAGE AMPLIFICATION

(2) Reference Impedance vs. Frequency

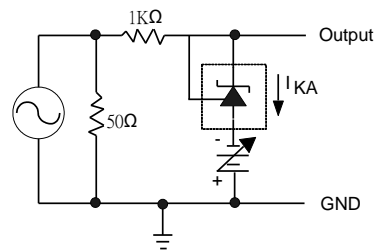
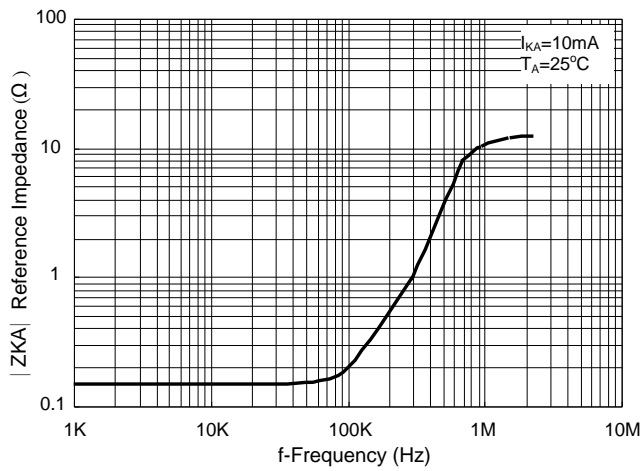

TEST CIRCUIT FOR REFERENCE IMPEDANCE

(3) Pulse Response

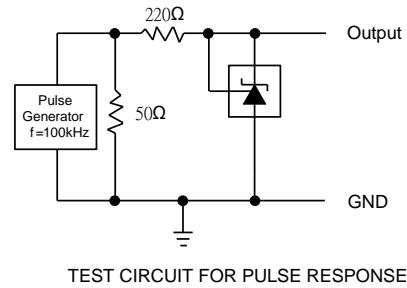
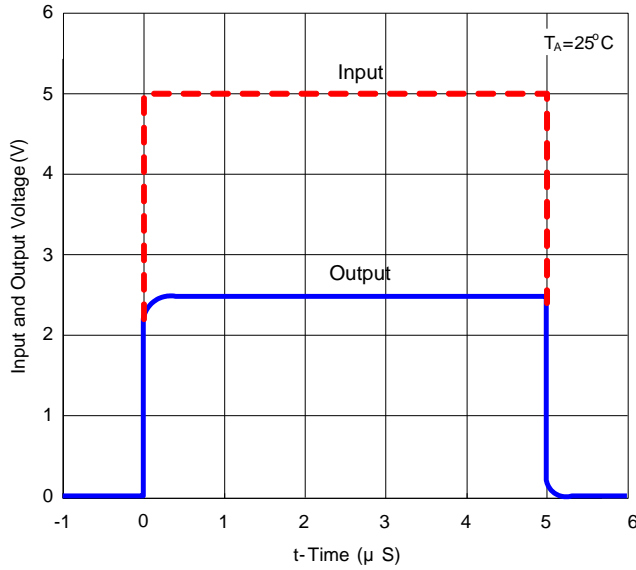

(4) Stability boundary conditions

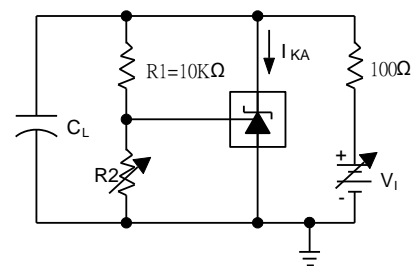
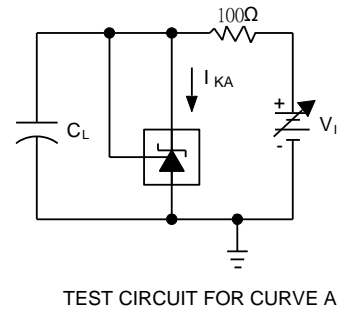
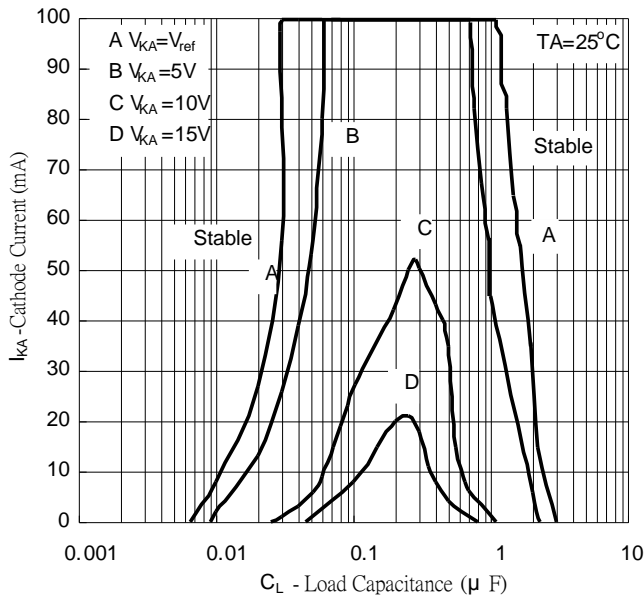

The areas under the curves represent conditions that may cause the device to oscillate. For curves B, C, and D, R2 and VI were adjusted to establish the initial VKA and IKA conditions with CL=0. VBATT and CL were then adjusted to determine the ranges of stability.

TEST CIRCUIT FOR CURVE B, C, AND D

❖ PACKAGE OUTLINES

(1) SOT-23-3L

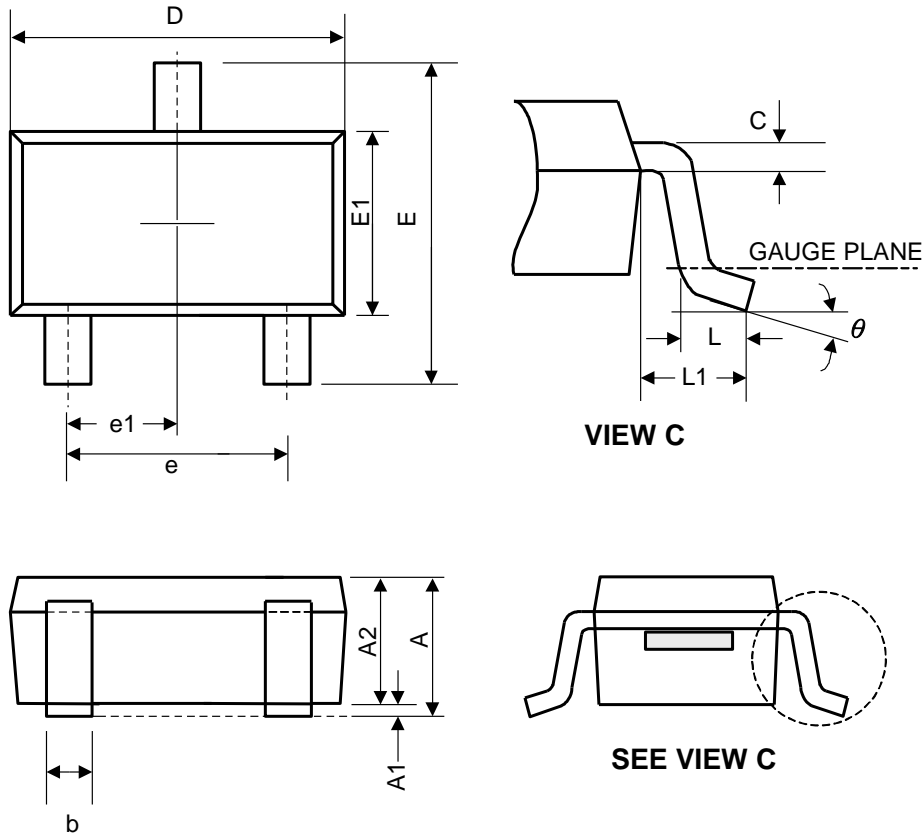

Symbol	Dimensions in Millimeters			Dimensions in Inches		
	Min.	Nom.	Max.	Min.	Nom.	Max.
A	-	-	1.45	-	-	0.057
A1	0.00	0.08	0.15	-	-	0.006
A2	0.90	1.10	1.30	0.035	0.043	0.051
b	0.30	0.40	0.50	0.012	0.016	0.020
C	0.08	0.15	0.22	0.003	0.006	0.009
D	2.70	2.90	3.10	0.106	0.114	0.122
E	2.60	2.80	3.00	0.102	0.110	0.118
E1	1.40	1.60	1.80	0.055	0.063	0.071
L	0.30	0.45	0.60	0.012	0.018	0.024
L1	0.50	0.60	0.70	0.020	0.024	0.028
e	1.9 BSC			0.075 BSC		
e1	0.95 BSC			0.037 BSC		
$\theta$	0°	4°	8°	0°	4°	8°

JEDEC outline: NA



(2) SOT-23-5L

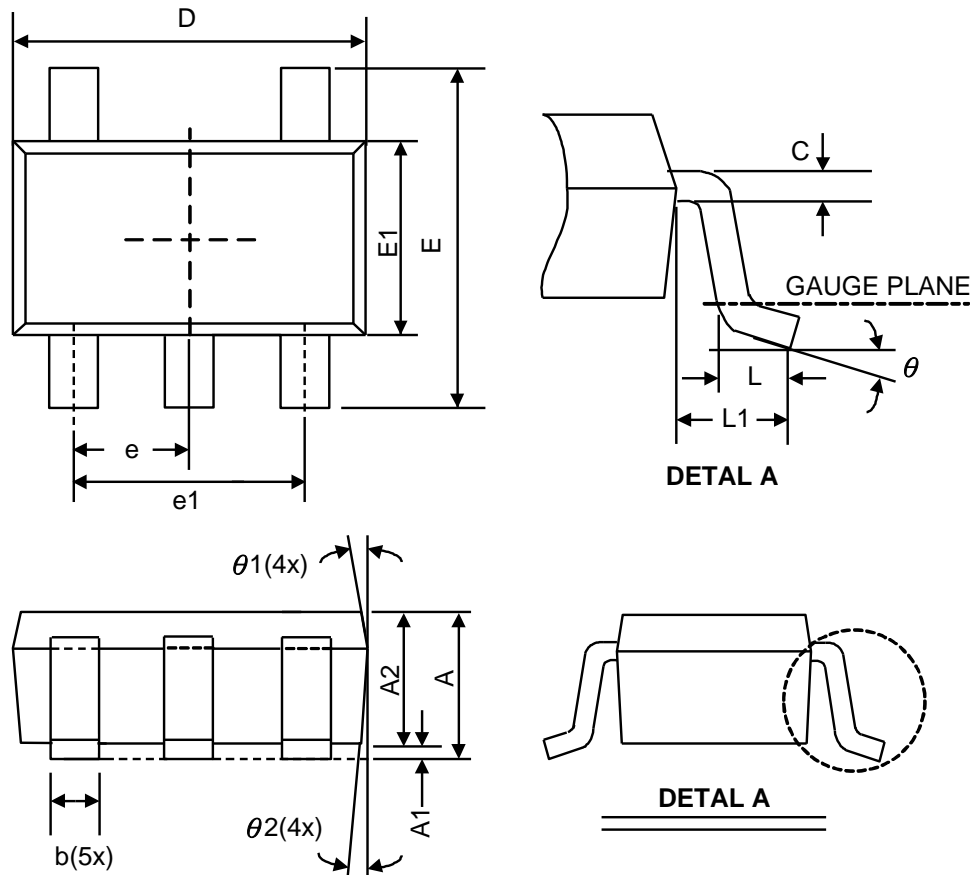

Symbol	Dimensions in Millimeters			Dimensions in Inches		
	Min.	Nom.	Max.	Min.	Nom.	Max.
A	-	-	1.45	-	-	0.057
A1	0.00	0.08	0.15	0	0.003	0.006
A2	0.90	1.10	1.30	0.035	0.043	0.051
b	0.30	0.40	0.50	0.012	0.016	0.020
C	0.08	0.15	0.22	0.003	0.006	0.009
D	2.70	2.90	3.10	0.106	0.114	0.122
E1	1.40	1.60	1.80	0.055	0.063	0.071
E	2.60	2.80	3.00	0.102	0.110	0.118
L	0.30	0.45	0.60	0.012	0.018	0.024
L1	0.50	0.60	0.70	0.020	0.024	0.028
e1	1.9 BSC			0.075 BSC		
e	0.95 BSC			0.037 BSC		
$\theta$	0°	4°	8°	0°	4°	8°
$\theta 1$	5°	10°	15°	5°	10°	15°
$\theta 2$	5°	10°	15°	5°	10°	15°

JEDEC outline: MO-178 AA