



B120 Thru B160

1 AMP SURFACE MOUNT SCHOTTKY BARRIER RECTIFIER

FEATURES

- For surface mount applications
- Metal semiconductor junction with guard ring
- Epitaxial construction
- Low forward voltage drop
- UL recognized 94V-O plastic material
- Lead solderable per MIL-STD-202 Method 208
- Surge overload rating to 30A peak

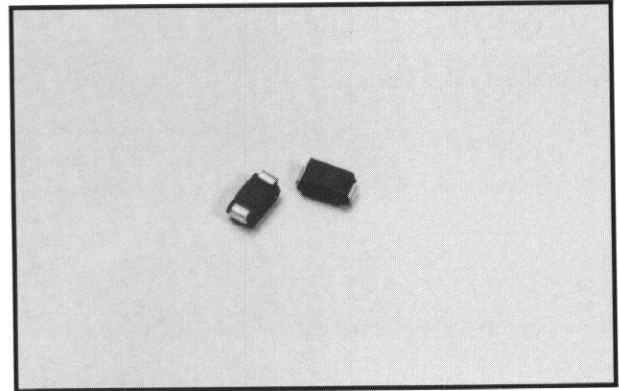

Outline Drawing

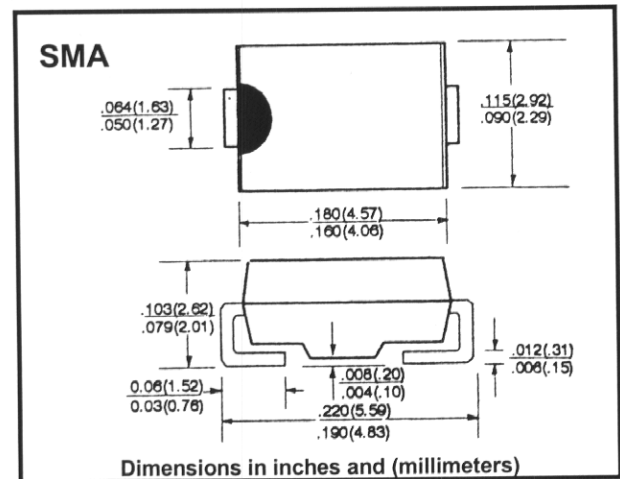

Mechanical Data

- Case: Molded plastic
- Polarity: Indicated on cathode
- Weight: 0.002 ounces, 0.064 grams

Maximum Ratings & Characteristics

- Ratings at 25° C ambient temperature unless otherwise specified
- Single phase, half wave, 60Hz, resistive or inductive load
- For capacitive load, derate current by 20%

		B120	B130	B140	B150	B160	Units
Maximum Recurrent Peak Reverse Voltage	V _{RRM}	20	30	40	50	60	V
Maximum RMS Input Voltage	V _{RMS}	14	21	28	35	42	V
Maximum DC Blocking Voltage	V _{DC}	20	30	40	50	60	V
Maximum Average Forward Output Current .375" 9.5mm lead length @ T _L = 100°C	I _(AV)	1.0					A
Peak Forward Surge Current 8.3 ms Single Half-Sine-Wave Superimposed On Rated Load	I _{FSM}	30					A
Maximum Forward Voltage Drop At 1.0A	V _F	0.50			0.70		V
Maximum Reverse Current At Rated DC Blocking Voltage per Bridge Element @ T _A = 25°C	I _R	0.5					mA
		1.0					mA
Typical Junction Capacitance *(See Note)	C _J	110					pF
Maximum Thermal Resistance**(See Note)	R _(THJL)	10					°C/W
Operating Temperature Range	T _J	-65 to +150					°C
Storage Temperature Range	T _{STG}	-65 to +150					°C

Note: *Measured at 1.0 MHz and applied reverse voltage of 4.0V DC

**Thermal resistance junction to lead, measured on PC board 5mm² X (0.013mm thick)