



FM24C02⁽¹⁾/04⁽²⁾/08⁽³⁾/16 ***2-Wire Serial EEPROM***

Data Sheet

Sep. 2009

- Note:**
- 1. FM24C02 not recommend for new design, please refer to FM24C02A datasheet.**
 - 2. FM24C04 not recommend for new design, please refer to FM24C04A datasheet.**
 - 3. FM24C08 not recommend for new design please refer to FM24C08A datasheet.**

INFORMATION IN THIS DOCUMENT IS INTENDED AS A REFERENCE TO ASSIST OUR CUSTOMERS IN THE SELECTION OF SHANGHAI FUDAN MICROELECTRONICS CO., LTD PRODUCT BEST SUITED TO THE CUSTOMER'S APPLICATION; THEY DO NOT CONVEY ANY LICENSE UNDER ANY INTELLECTUAL PROPERTY RIGHTS, OR ANY OTHER RIGHTS, BELONGING TO SHANGHAI FUDAN MICROELECTRONICS CO., LTD OR A THIRD PARTY. WHEN USING THE INFORMATION CONTAINED IN THIS DOCUMENTS, PLEASE BE SURE TO EVALUATE ALL INFORMATION AS A TOTAL SYSTEM BEFORE MAKING A FINAL DECISION ON THE APPLICABILITY OF THE INFORMATION AND PRODUCTS. SHANGHAI FUDAN MICROELECTRONICS CO., LTD ASSUMES NO RESPONSIBILITY FOR ANY DAMAGE, LIABILITY OR OTHER LOSS RESULTING FROM THE INFORMATION CONTAINED HEREIN. SHANGHAI FUDAN MICROELECTRONICS CO., LTD PRODUCTS ARE NOT INTENDED FOR USE IN MEDICAL, LIFE SAVING, OR LIFE SUSTAINING APPLICATIONS. THE PRIOR WRITTEN APPROVAL OF SHANGHAI FUDAN MICROELECTRONICS CO., LTD IS NECESSARY TO REPRINT OR REPRODUCE IN WHOLE OR IN PART THESE DOCUMENTS.

Future routine revisions will occur when appropriate, without notice. Contact Shanghai Fudan Microelectronics Co., Ltd sales office to obtain the latest specifications and before placing your product order. Please also pay attention to information published by Shanghai Fudan Microelectronics Co., Ltd by various means, including Shanghai Fudan Microelectronics Co., Ltd home page (<http://www.fmsh.com/>).

Please contact Shanghai Fudan Microelectronics Co., Ltd local sales office for the specification regarding the information in this documents or Shanghai Fudan Microelectronics Co., Ltd products.

Trademarks

Shanghai Fudan Microelectronics Co., Ltd name and logo, the “复旦” logo are trademarks or registered trademarks of Shanghai Fudan Microelectronics Co., Ltd or its subsidiaries in China.

Shanghai Fudan Microelectronics Co., Ltd, Printed in the China, All Rights Reserved.

Description

The FM24C02/04/08/16 provides 2048/4096/8192/16384 bits of serial electrically erasable and programmable read-only memory (EEPROM) organized as 256/512/1024/2048 words of 8 bits each. The device is optimized for use in many industrial and commercial applications where low-power and low-voltage operations are essential.

Features

- Operation Voltage: 2.2V to 5.5V
- Internally Organized: 256 x 8 (2K), 512 x 8 (4K), 1024 x 8 (8K) or 2048 x 8 (16K)
- 2-wire Serial Interface
- Schmitt Trigger, Filtered Inputs for Noise Suppression
- Bi-directional Data Transfer Protocol
- 100 kHz (2.2V) and 400 kHz (5V) Compatibility
- Write Protect Pin for Hardware Data Protection
- 8-byte Page (02), 16-byte Page (04, 08, 16) Write Modes
- Partial Page Writes are Allowed
- Self-timed Write Cycle (5 ms max)
- High-reliability
 - Endurance: 1,000,000 Write Cycles
 - Data Retention: 100 Years
- PDIP8, SOP8, TSSOP8 Packages (RoHS Compliant and Halogen-free)

Absolute Maximum Ratings

Operating Temperature (Plastic Package)	-55°C to +125°C
Operating Temperature (Module Package)	-20°C to +60°C
Storage Temperature (Plastic Package)	-65°C to +150°C
Storage Temperature (Module Package)	-25°C to +70°C
Voltage on Any Pin with Respect to Ground	-1.0V to +7.0V
Maximum Operating Voltage	6.25V
DC Output Current	5.0 mA

*NOTICE: Stresses beyond those listed under "Absolute Maximum Ratings" may cause permanent damage to the device. This is a stress rating only and functional operation of the device at these or any other conditions beyond those indicated in the operational sections of this specification are not implied. Exposure to absolute maximum rating conditions for extended periods may affect device reliability.

上海复旦微电子股份有限公司
SHANGHAI FUDAN MICROELECTRONICS CO., LTD.

FM24C02/04/08/16 2-Wire Serial EEPROM

Packaging Type

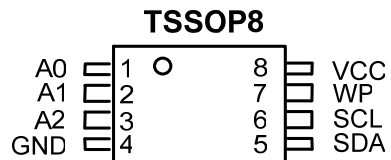
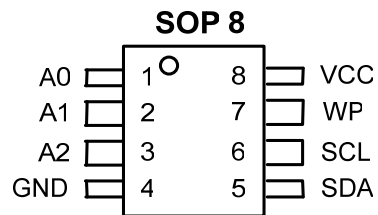
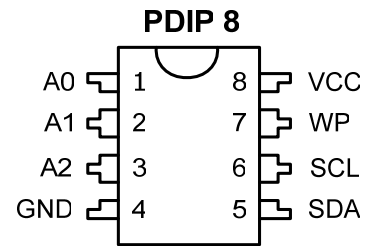

Module package (8 Pin)

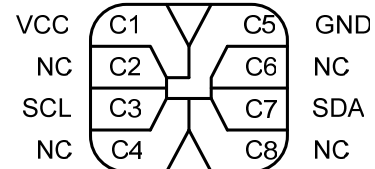

Module package (6 Pin)

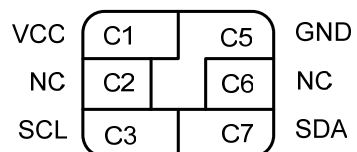

Pin Configurations

Pin Name	Function
A0~A2	Device Address Inputs
SDA	Serial Data Input/Output
SCL	Serial Clock Input
WP	Write Protect
VCC	Power Supply
GND	Ground
NC	Not Connect

Figure 1. Block Diagram

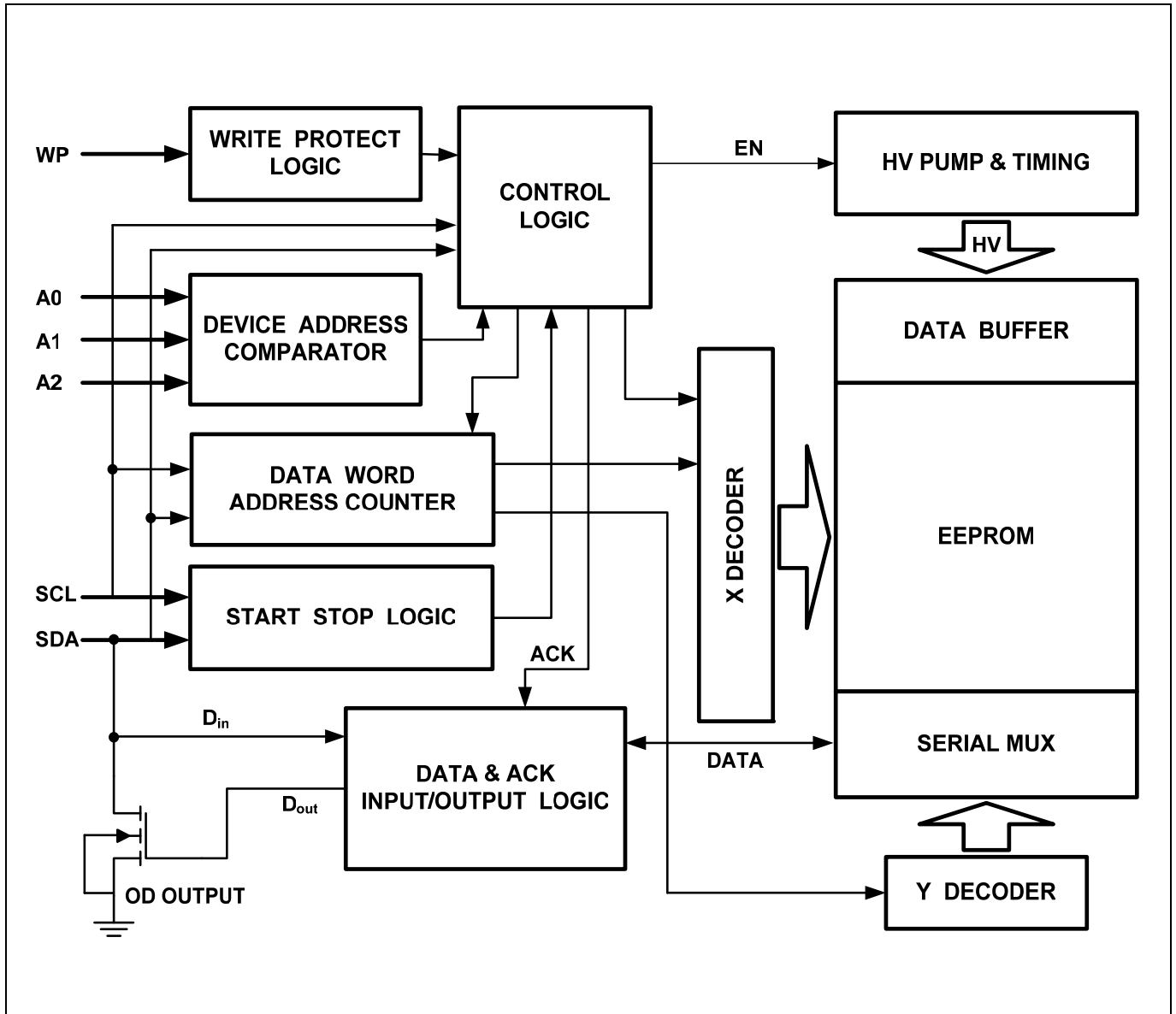

Pin Description

SERIAL CLOCK (SCL): The SCL input is used to positive edge clock data into each EEPROM device and negative edge clock data out of each device.

SERIAL DATA (SDA): The SDA pin is bi-directional for serial data transfer. This pin is open-drain driven and may be wire-ORed with any number of other open-drain or open-collector devices.

DEVICE/PAGE ADDRESSES (A2, A1, A0): The A2, A1 and A0 pins are device address inputs that are hard wired for the FM24C02. As many as eight 2K devices may be addressed on a single bus system (device addressing is discussed in detail under the Device Addressing section).

The FM24C04 uses the A2 input for hardwire addressing and a total of two 4K devices may be addressed on a single bus system. The A0 and A1

pins are no connects.

The FM24C08 only uses the A2 input for hardwire addressing and a total of two 8K devices may be addressed on a single bus system. The A0 and A1 pins are no connects.

The FM24C16 does not use the device address pins, which limits the number of devices on a single bus to one. The A0, A1 and A2 pins are no connects.

WRITE PROTECT (WP): The FM24C02/04/08/16 has a Write Protect pin that provides hardware data protection. The Write Protect pin allows normal read/write operations when connected to ground (GND). When the Write Protect pin is connected to V_{CC} , the write protection feature is enabled.

Write Protect Description

WP Pin Status	Part of the Array Protected			
	FM24C02	FM 24C04	FM 24C08	FM 24C16
WP= V_{CC}	Full (2K) Array	Full (4K) Array	Full (8K) Array	Upper Half (8K) Array
WP=GND	Normal Read/Write Operations			

Memory Organization

FM24C02, 2K SERIAL EEPROM: Internally organized with 32 pages of 8 bytes each, the 2K requires an 8-bit data word address for random word addressing.

FM24C04, 4K SERIAL EEPROM: Internally organized with 32 pages of 16 bytes each, the 4K requires a 9-bit data word address for random word addressing.

FM24C08, 8K SERIAL EEPROM: Internally organized with 64 pages of 16 bytes each, the 8K requires a 10-bit data word address for random word addressing.

FM24C16, 16K SERIAL EEPROM: Internally organized with 128 pages of 16 bytes each, the 16K requires an 11-bit data word address for random word addressing.

Pin Capacitance

Applicable over recommended operating range from: $T_A = 25^\circ\text{C}$, $f = 1.0\text{ MHz}$, $V_{CC} = +2.2\text{V}$.

Symbol	Test Condition	Max	Units	Conditions
$C_{I/O}^1$	Input/Output Capacitance (SDA)	8	pF	$V_{I/O} = 0\text{V}$
C_{IN}^1	Input Capacitance ($A_0, A_1, A_2, \text{SCL}$)	6	pF	$V_{IN} = 0\text{V}$

Note: 1. This parameter is characterized and is not 100% tested.

DC Characteristics

Applicable over recommended operating range from: $T_A = -40^\circ\text{C}$ to $+85^\circ\text{C}$, $V_{CC} = +2.2\text{V}$ to $+5.5\text{V}$, (unless otherwise noted).

Symbol	Parameter	Test Condition	Min	Typ	Max	Units
V_{CC}	Supply Voltage		2.2		5.5	V
I_{CC1}	Supply Current	$V_{CC} = 5.0\text{V}$, Read at 100K		0.4	1.0	mA
I_{CC2}	Supply Current	$V_{CC} = 5.0\text{V}$, Write at 100K		2.0	3.0	mA
I_{SB1}	Standby Current	$V_{CC} = 2.2\text{V}$, $V_{IN} = V_{CC}/V_{SS}$			1.0	μA
I_{SB2}	Standby Current	$V_{CC} = 5.0\text{V}$, $V_{IN} = V_{CC}/V_{SS}$			6.0	μA
I_{LI}	Input Leakage Current	$V_{IN} = V_{CC}/V_{SS}$		0.10	3.0	μA
I_{LO}	Output Leakage Current	$V_{OUT} = V_{CC}/V_{SS}$		0.05	3.0	μA
V_{IL}^1	Input Low Level		-0.6		$V_{CC} \times 0.3$	V
V_{IH}^1	Input High Level		$V_{CC} \times 0.7$		$V_{CC} + 0.5$	V
V_{OL}	Output Low Level	$V_{CC} = 2.7\text{V}$, $I_{OL} = 2.1\text{ mA}$			0.4	V

Note: 1. V_{IL} min and V_{IH} max are reference only and are not tested.

AC Characteristics

Applicable over recommended operating range from: $T_A = -40^{\circ}\text{C}$ to $+85^{\circ}\text{C}$, $V_{CC} = +2.2\text{V}$ to $+5.5\text{V}$, $CL = 1$ TTL Gate and 100 pF (unless otherwise noted). Test conditions are listed in Note 2.

Symbol	Parameter	2.2-volt		5.0-volt		Units
		Min	Max	Min	Max	
f_{SCL}	Clock Frequency, SCL		100		400	kHz
t_{LOW}	Clock Pulse Width Low	4.7		1.2		μs
t_{HIGH}	Clock Pulse Width High	4.0		0.6		μs
t_{AA}	Clock Low to Data Out Valid	0.1	4.5	0.1	0.9	μs
t_{BUF}^1	Time the bus must be free before a new transmission can Start	4.7		1.2		μs
$t_{HD.STA}$	Start Hold Time	4.0		0.6		μs
$t_{SU.STA}$	Start Setup Time	4.7		0.6		μs
$t_{HD.DAT}$	Data In Hold Time	0		0		μs
$t_{SU.DAT}$	Data In Setup Time	200		100		ns
t_R	Inputs Rise Time		1.0		0.3	μs
t_F	Inputs Fall Time		300		300	ns
$t_{SU.STO}$	Stop Setup Time	4.7		0.6		μs
t_{DH}	Data Out Hold Time	100		50		ns
t_{WR}	Write Cycle Time		5		5	ms
Endurance ¹	5.0V, 25°C, Page Mode	1,000,000				Write Cycles

Notes: 1. This parameter is characterized and is not 100% tested.

2. AC measurement conditions:

RL (connects to V_{CC}): 1.3 k Ω

Input pulse voltages: 0.3 V_{CC} to 0.7 V_{CC}

Input rise and fall times: ≤ 50 ns

Input and output timing reference voltages: 0.5 V_{CC}

Device Operation

CLOCK and DATA TRANSITIONS: The SDA pin is normally pulled high with an external device. Data on the SDA pin may change only during SCL low time periods (refer to Figure 4). Data changes during SCL high periods will indicate a start or stop condition as defined below.

START CONDITION: A high-to-low transition of SDA with SCL high is a start condition which must precede any other command (refer to Figure 5).

STOP CONDITION: A low-to-high transition of SDA with SCL high is a stop condition. After a read sequence, the stop command will place the EEPROM in a standby power mode (refer to Figure 5).

All addresses and data words are serially transmitted to and from the EEPROM in 8-bit words. The EEPROM sends a zero to acknowledge that it has received each word. This happens during the ninth

clock cycle. Following receipt each word from the EEPROM, the microcontroller should send a zero to EEPROM and continue to output the next data word or send a stop condition to finish the read cycle.

STANDBY MODE: The FM24C02/04/08/16 features a low-power standby mode which is enabled: (a) upon power-up and (b) after the receipt of the stop bit and the completion of any internal operations.

DEVICE RESET: After an interruption in protocol, power loss or system reset, any 2-wire part can be protocol reset by following these steps:

1. Clock up to 9 cycles.
2. Look for SDA high in each cycle while SCL is high.
3. Create a start condition.

Bus Timing

Figure 2. SCL: Serial Clock, SDA: Serial Data I/O

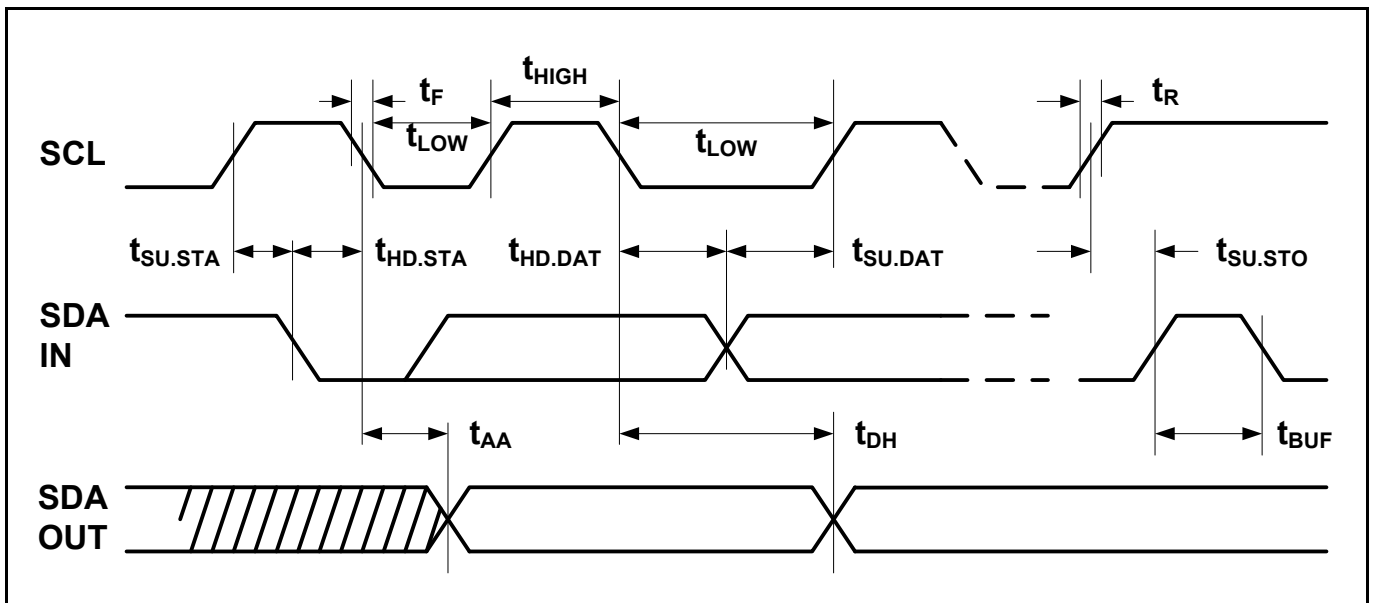

Write Cycle Timing

Figure 3. SCL: Serial Clock, SDA: Serial Data I/O

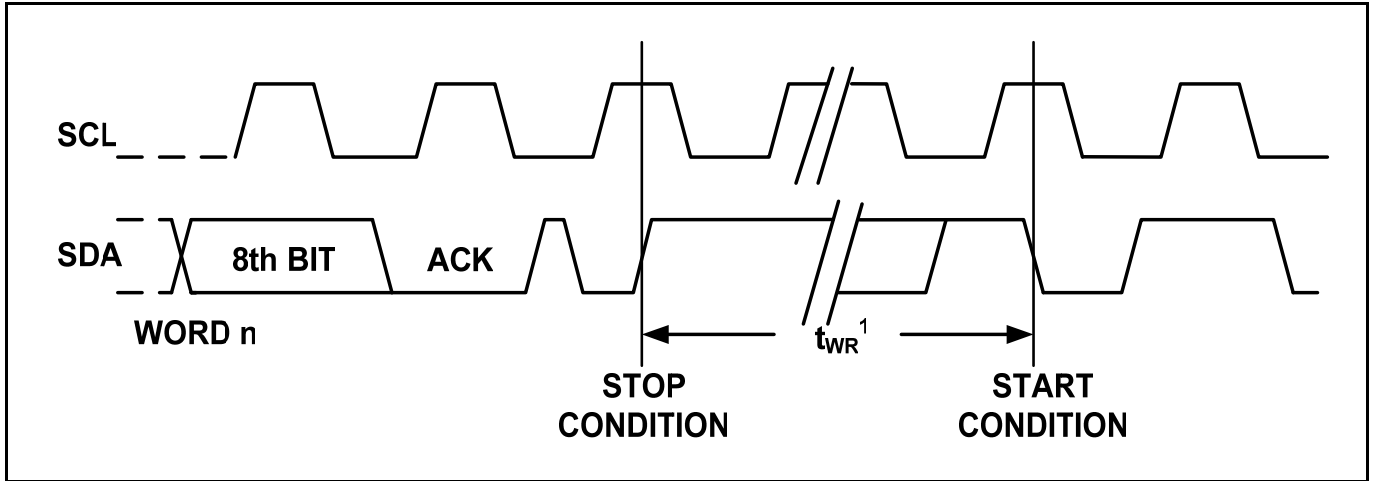

Note: 1. The write cycle time t_{WR} is the time from a valid stop condition of a write sequence to the end of the internal clear/write cycle.

Figure 4. Data Validity

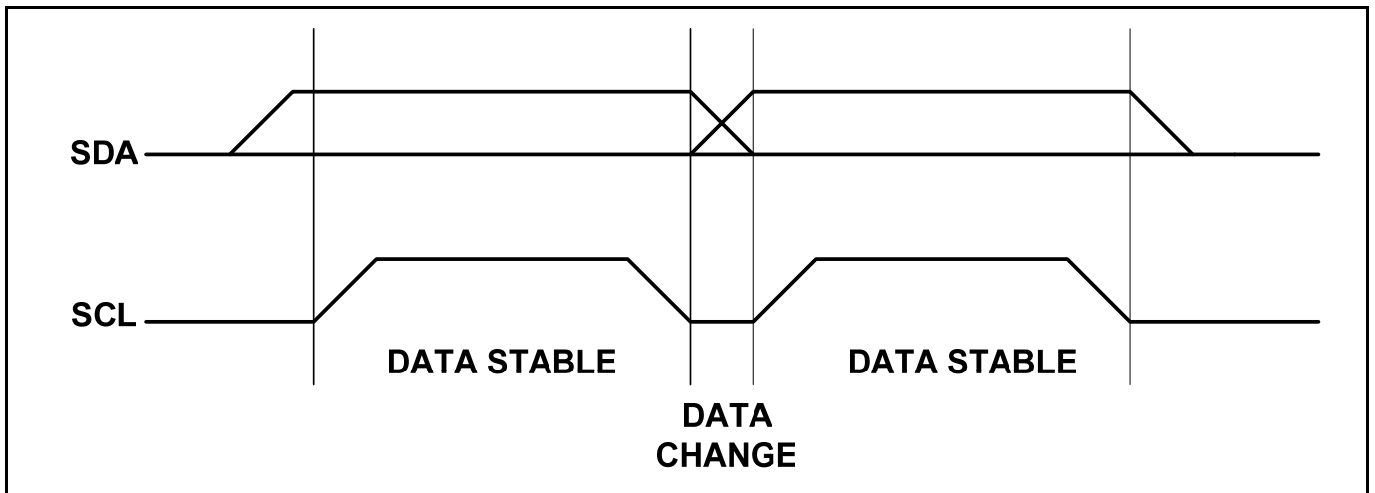

Figure 5. Start and Stop Definition

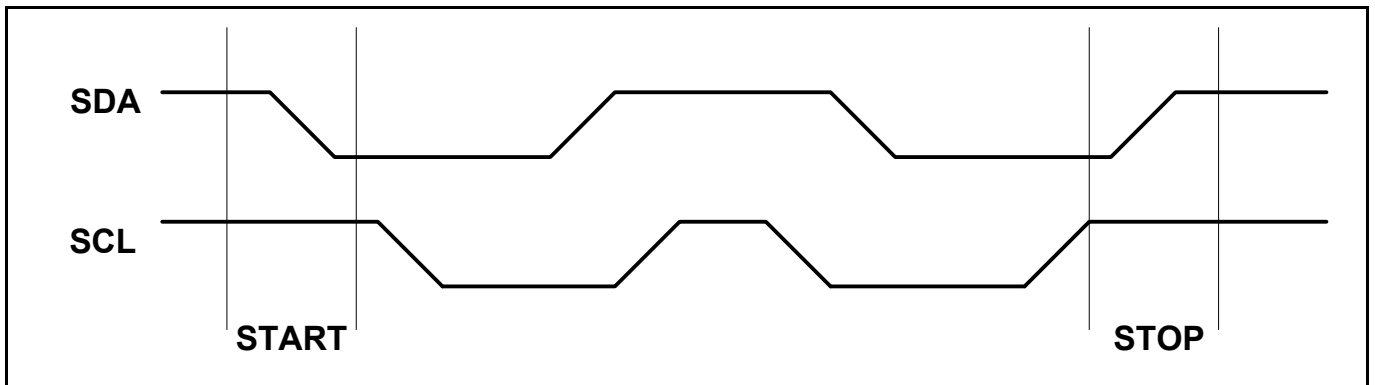
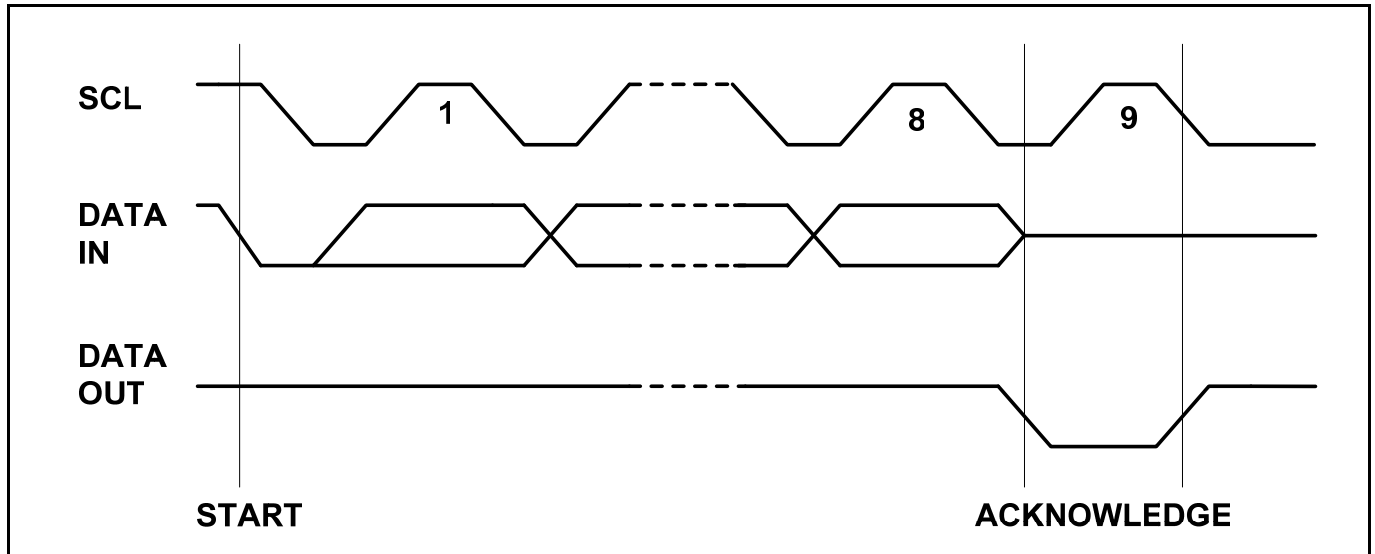

Figure 6. Output Acknowledge



Device Addressing

The 2K, 4K, 8K and 16K EEPROM devices all require an 8-bit device address word following a start condition to enable the chip for a read or write operation (refer to Figure 7).

The device address word consists of a mandatory one, zero sequence for the first four most significant bits as shown. This is common to all the EEPROM devices.

The next 3 bits are the A2, A1 and A0 device address bits for the 2K EEPROM. These 3 bits must compare to their corresponding hard-wired input pins.

The 4K EEPROM only uses the A2 for device addressing. The second bit is don't care bit and the third bit is a memory page address bit. The A2 bit must compare to its corresponding hard-wired input pin. The A1 and A0 pins are no connecting.

The 8K EEPROM only uses the A2 device address bit with the next 2 bits being for memory page addressing. The A2 bit must compare to its corresponding hard-wired input pin. The A1 and A0 pins are no connecting.

The 16K does not use any device address bits but instead the 3 bits are used for memory page addressing. These page addressing bits on the 4K, 8K and 16K devices should be considered the most significant bits of the data word address which follows. The A0, A1 and A2 pins are no connecting.

The eighth bit of the device address is the read/write operation select bit. A read operation is initiated if this bit is high and a write operation is initiated if this bit is low.

The Module package device address word also consists of a mandatory one, zero sequence for the first four most significant bits. The next 3 bits are all zero.

Upon a compare of the device address, the EEPROM will output a zero. If a compare is not made, the chip will return to a standby state.

Write Operations

BYTE WRITE: A write operation requires an 8-bit data word address following the device address word and acknowledgment. Upon receipt of this address, the EEPROM will again respond with a zero and then clock in the first 8-bit data word. Following receipt of the 8-bit data word, the EEPROM will output a zero and the addressing device, such as a microcontroller, must terminate the write sequence with a stop condition. At this time the EEPROM enters an internally timed write cycle, t_{WR} , to the nonvolatile memory. All inputs are disabled during this write cycle and the EEPROM will not respond until the write is complete (refer to Figure 8).

PAGE WRITE: The 2K EEPROM is capable of an 8-byte page write, and the 4K, 8K and 16K devices are capable of 16-byte page writes.

A page write is initiated the same as a byte write, but the microcontroller does not send a stop condition after the first data word is clocked in. Instead, after the EEPROM acknowledges receipt of the first data word, the microcontroller can transmit up to seven (2K) or fifteen (4K, 8K, 16K) more data words. The EEPROM will respond with a zero after each data word received. The microcontroller must terminate the page write sequence with a stop condition (refer to Figure 9).

The data word address lower three (2K) or four (4K, 8K, 16K) bits are internally incremented following the receipt of each data word. The higher data word address bits are not incremented, retaining the memory page row location. When the word address, internally generated, reaches the page boundary, the following byte is placed at the beginning of the same page. If more than eight (2K) or sixteen (4K, 8K, 16K) data words are transmitted to the EEPROM, the data word address will “roll over” and previous data will be overwritten.

ACKNOWLEDGE POLLING: Once the internally timed write cycle has started and the EEPROM inputs are disabled, acknowledge polling can be initiated. This involves sending a start condition followed by the device address word. The read/write bit is representative of the operation desired. Only if the internal write cycle has completed will the EEPROM respond with a zero allowing the read or write sequence to continue.

Read Operations

Read operations are initiated the same way as write operations with the exception that the read/write select bit in the device address word is set to one. There are three read operations: current address read, random address read and sequential read.

CURRENT ADDRESS READ: The internal data word address counter maintains the last address accessed during the last read or write operation, incremented by one. This address stays valid between operations as long as the chip power is maintained. The address “roll over” during read is from the last byte of the last memory page to the first byte of the first page. The address “roll over” during write is from the last byte of the current page to the first byte of the same page.

Once the device address with the read/write select bit set to one is clocked in and acknowledged by the EEPROM, the current address data word is serially clocked out. The microcontroller does not respond with an input zero but does generate a following stop condition (refer to Figure 10).

RANDOM READ: A random read requires a “dummy” byte write sequence to load in the data word address. Once the device address word and data word address are clocked in and acknowledged by the EEPROM, the microcontroller must generate another start condition. The microcontroller now initiates a current address read by sending a device address with the read/write select bit high. The EEPROM acknowledges the device address and serially clocks out the data word. The microcontroller does not respond with a zero but does generate a following stop condition (refer to Figure 11).

SEQUENTIAL READ: Sequential reads are initiated by either a current address read or a random address read. After the microcontroller receives a data word, it responds with an acknowledge. As long as the EEPROM receives an acknowledge, it will continue to increment the data word address and serially clock out sequential data words. When the memory address limit (2K, 8K, 16K) is reached, the data word address will “roll over” and the sequential read will continue. The sequential read operation is terminated when the microcontroller does not respond with a zero but does generate a following stop condition (refer to Figure 12).

Figure 7. Device Address

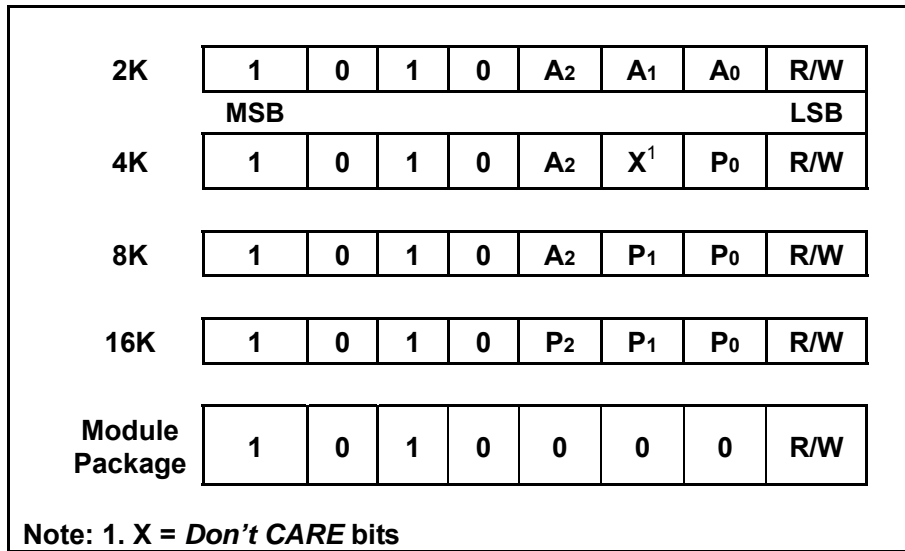

Figure 8. Byte Write

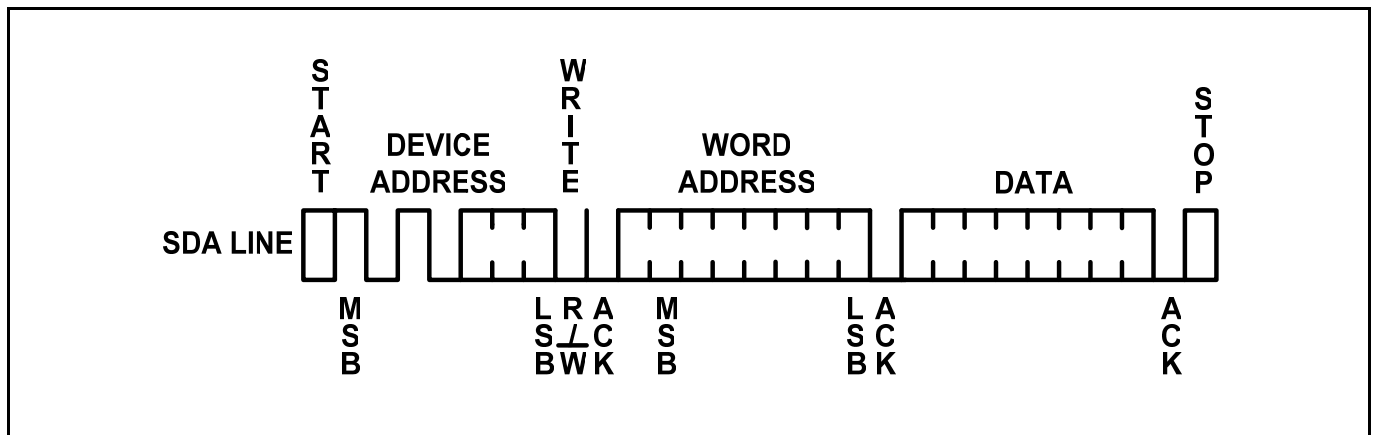

Figure 9. Page Write

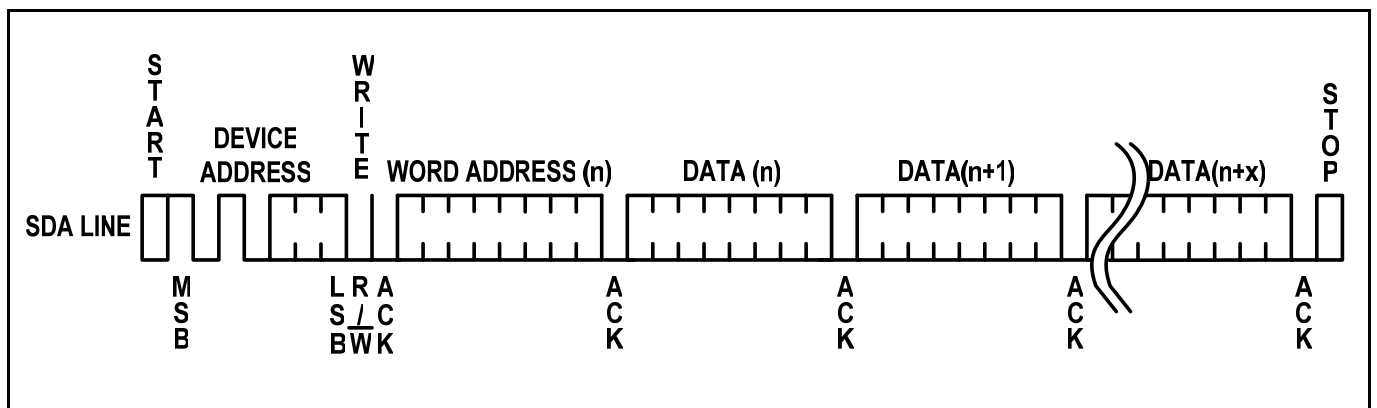

Figure 10. Current Address Read

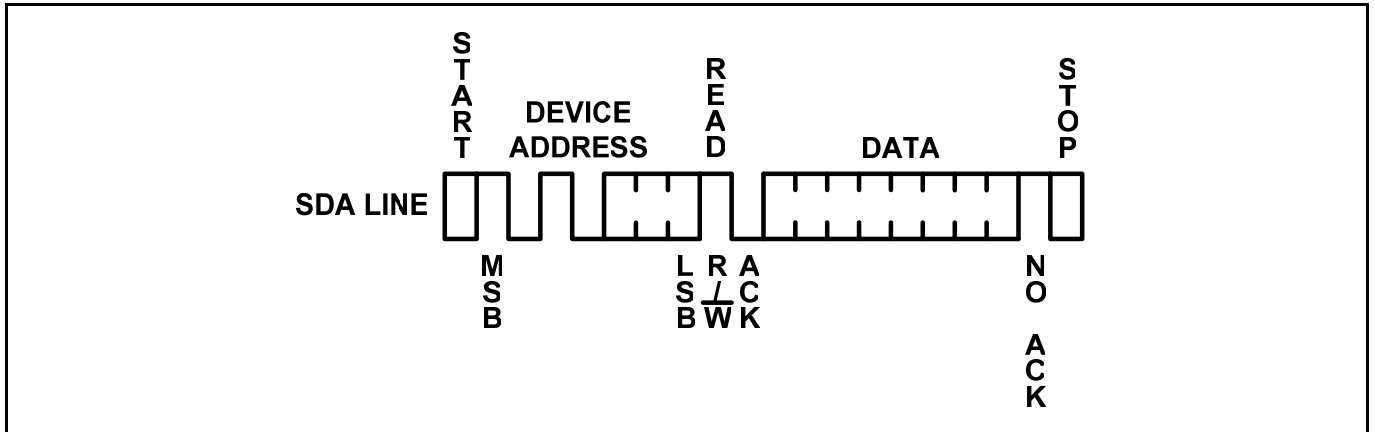

Figure 11. Random Read

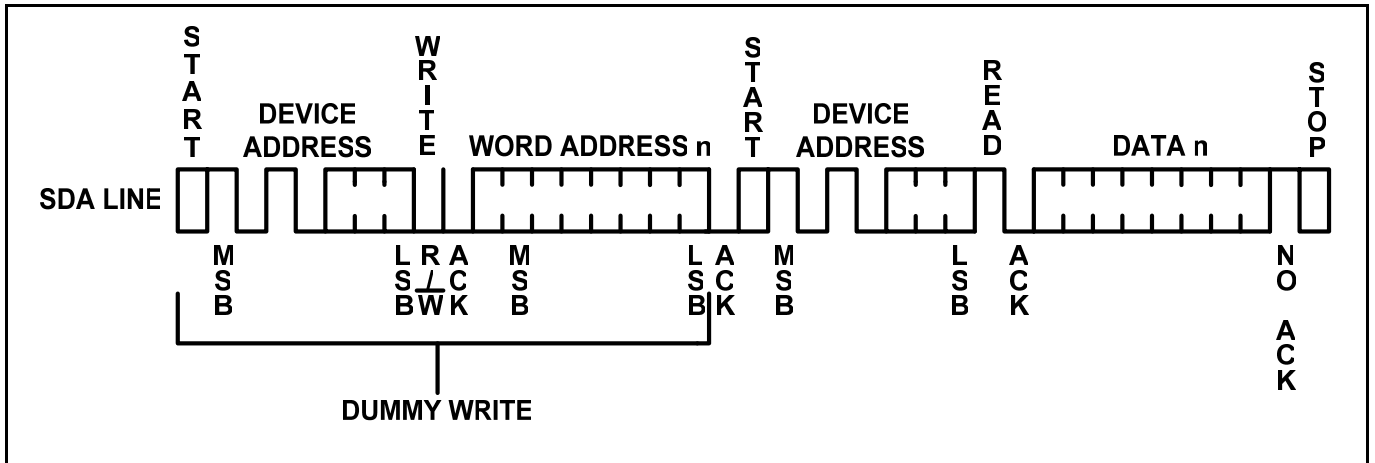
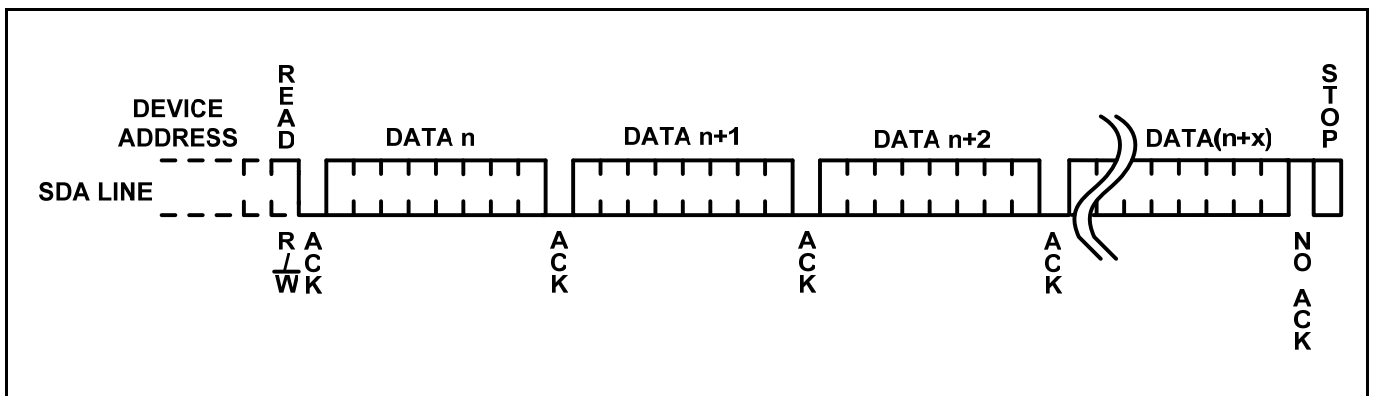

Figure 12. Sequential Read





Ordering Information

	FM	24C	DD	-PP	-C	-H
Company Prefix						
FM = Fudan Microelectronics Co.,Ltd						
Product Family						
24C = 2- Wire Serial EEPROM						
Product Density						
02 = 2K-bit 04 = 4K-bit 08 = 8K-bit 16 = 16K-bit						
Package Type						
PD = 8-pin PDIP SO = 8-pin SOP TS = 8-pin TSSOP						
M2F or M2P = 8-pin Module Package ⁽¹⁾ M3F or M3P = 6-pin Module Package ⁽¹⁾						
Product Carrier						
U = Tube T = Tape and Reel R = Module Reel						
HSF ID Code						
Blank or R = RoHS Compliant G = RoHS Compliant, Halogen-free, Antimony-free						

Note: 1. For the details of Module package please contact local sales office.

Part Marking Scheme

PDIP8

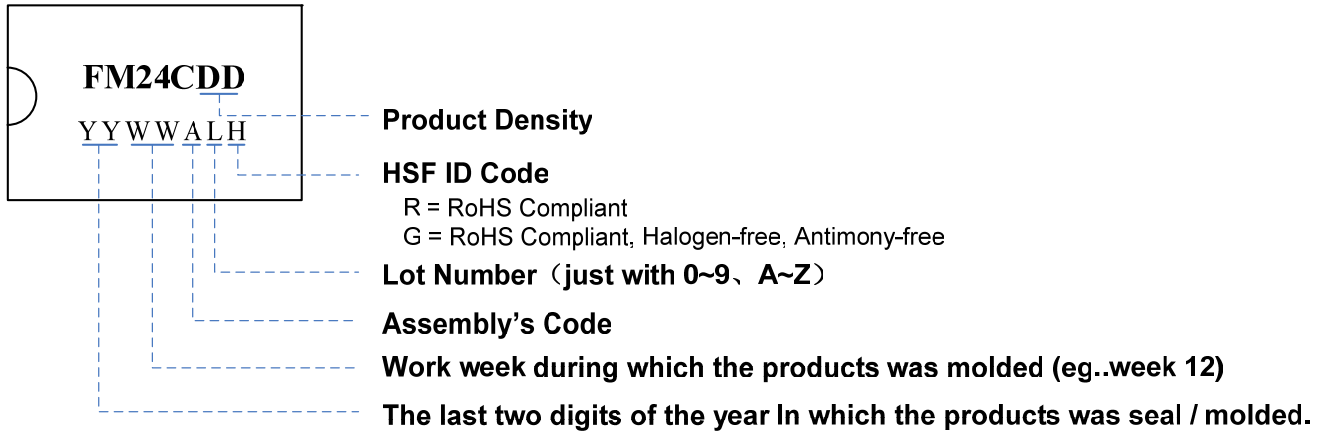

SOP8

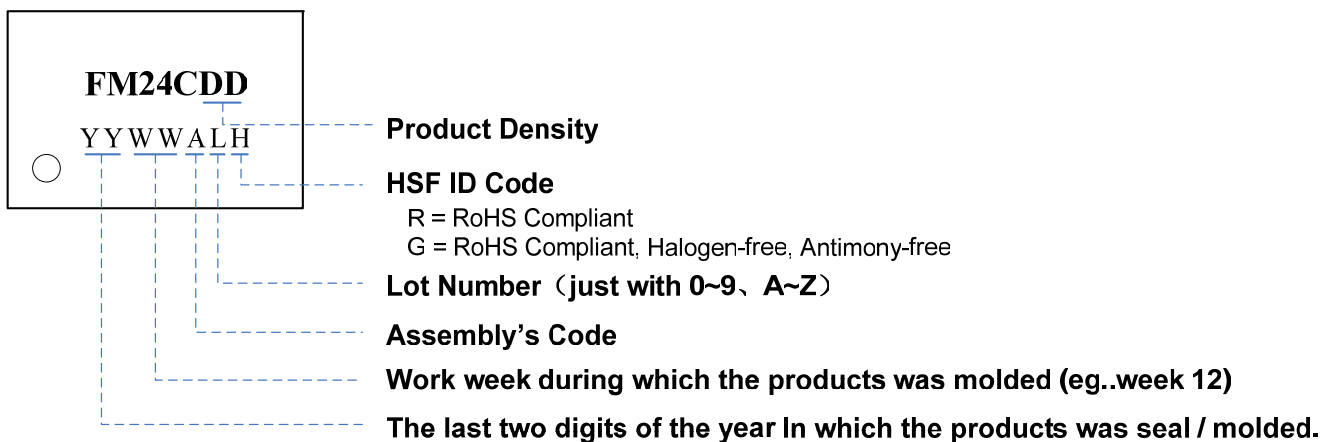

TSSOP8

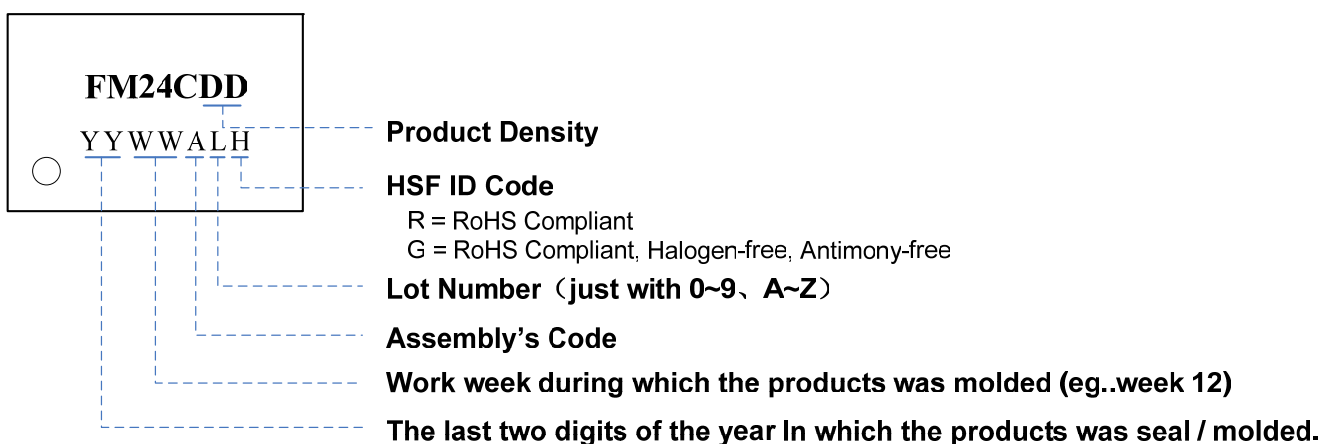

Packaging Information

PDIP 8

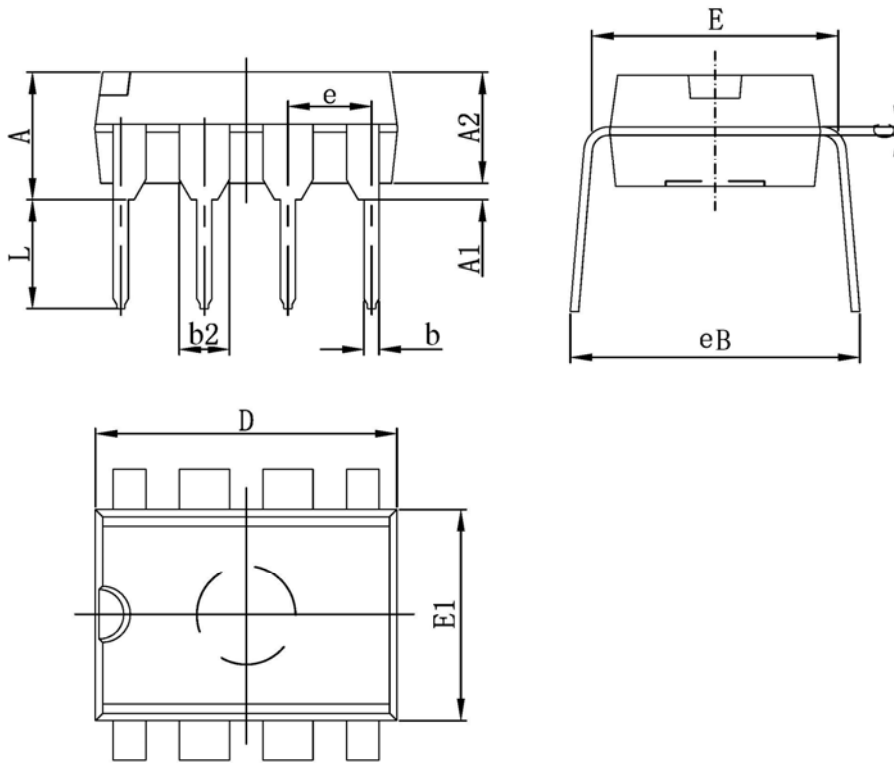

Symbol	MIN	MAX
A	3.710	4.310
A1	0.510	
A2	3.200	3.600
b	0.380	0.570
b2	1.524(BSC)	
C	0.204	0.360
D	9.000	9.400
E1	6.200	6.600
E	7.320	7.920
e	2.540(BSC)	
L	3.000	3.600
eB	8.400	9.000

NOTE:

- Dimensions are in Millimeters.

SOP 8

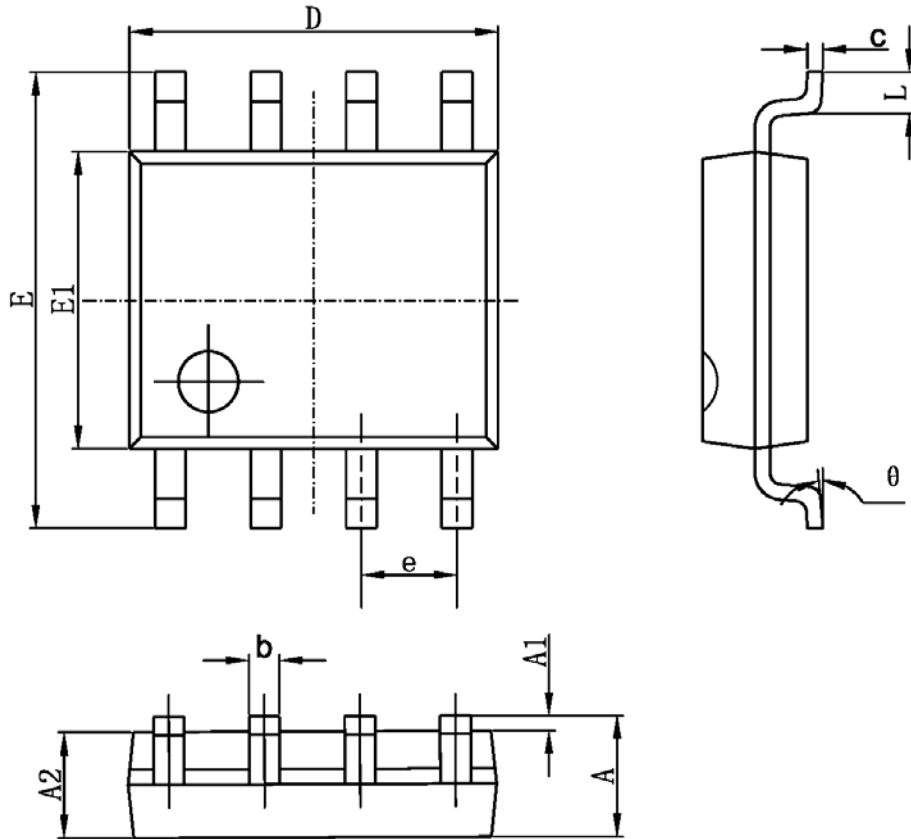

Symbol	MIN	MAX
A	1.350	1.750
A1	0.100	0.250
A2	1.350	1.550
b	0.330	0.510
c	0.170	0.250
D	4.700	5.100
E1	3.800	4.000
E	5.800	6.200
e	1.270(BSC)	
L	0.400	1.270
θ	0°	8°

NOTE:

1. Dimensions are in Millimeters.

TSSOP8

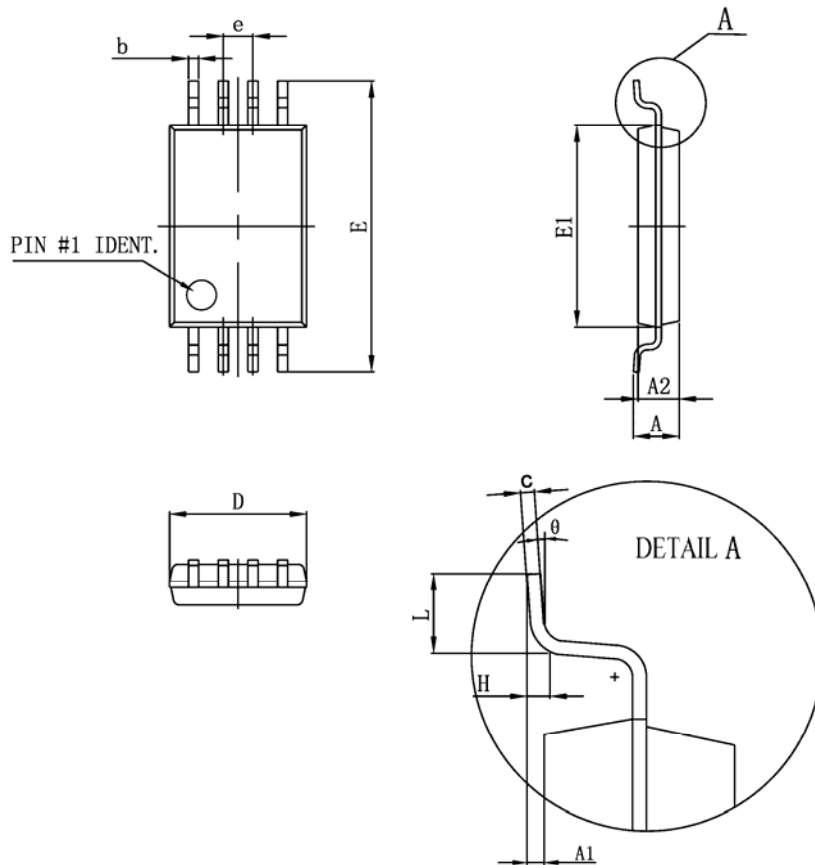

Symbol	MIN	MAX
D	2.900	3.100
E1	4.300	4.500
b	0.190	0.300
c	0.090	0.200
E	6.250	6.550
A		1.100
A2	0.800	1.000
A1	0.050	0.150
e	0.650 (BSC)	
L	0.500	0.700
H	0.250 (TYP)	
θ	1°	7°

NOTE:

1. Dimensions are in Millimeters.



Revision History

Version	Publication date	Pages	Paragraph or Illustration	Revise Description
1.0	Sep. 2005	17		Initial Release.
2.0	Dec. 2006	19	"Feature" "Package Type" DC and AC Characteristics "package information" "Ordering Information"	1. Updated the endurance, data retention and the lowest voltage. Added the description of package type and wafer sales. 2. Added the Pin assignment and package dimension of TSSOP8 and the Pin assignment of module package (6pin). 3. Updated "DC and AC Characteristics", added the AC measurement conditions. 4. Updated the ordering information, added the products carrier.
2.1	Apr. 2007	19	"ordering information" "Sales and service"	1. Updated the ordering information, added the tube carrier for TSSOP product 2. Updated the address and phone number of Shenzhen Office
2.2	May. 2007	19	"Pin description" "Device addressing" "Figure 7"	1. Updated the description of device addressing.
3.0	Apr. 2008	19	"Feature" "Ordering information"	1. Removed the description for wafer sale. 2. Removed the description of FM24C08A parts, 3. Added 'FM24C04/08 not recommended for new design' note to page 1.
3.1	May. 2008	19	"Absolute maximum ratings" "Ordering Information" "Sales and Service"	1. Added the absolute maximum ratings for module package. 2. Removed the module package ordering information of FM24C04. 3. Updated the ordering code for module package 4. Updated the address of HK office.
3.2	Feb. 2009	20	"Features" "Ordering Information" "Part Marking Scheme" "Sales and Service"	1. Added the information of Halogen-free 2. Updated the "Ordering Information" 3. Added the "Part Marking Scheme" 4. Updated the address of Beijing office.
3.3	July. 2009	20		1. Added 'FM24C02 not recommended for new design' note to page 1.
3.4	Sep. 2009	20	"Device Addressing" "Packaging Information"	1. Added the description of device addressing for Module package device. 2. Updated the Packaging Information.



Sales and Service

Shanghai Fudan Microelectronics Co., Ltd.

Address: Bldg No. 4, 127 Guotai Rd,
Shanghai City China.

Postcode: 200433

Tel: (86-021) 6565 5050

Fax: (86-021) 6565 9115

Shanghai Fudan Microelectronics (HK) Co., Ltd.

Address: Unit 506, 5/F., East Ocean Centre, 98 Granville
Road, Tsimshatsui East, Kowloon, Hong Kong

Tel: (852) 2116 3288 2116 3338

Fax: (852) 2116 0882

Beijing Office

Address: Room 419E, Bldg B, Gehua Building,
1 QingLong Hutong, Dongzhimen Alley north Street,
Dongcheng District, Beijing City, China.

Postcode: 100007

Tel: (86-10) 8418 6608 8418 7486

Fax: (86-10) 8418 6211

Shenzhen Office

Address: Room.1301, Century Bldg, Shengtingyuan Hotel,
Huaqiang Rd (North),
Shenzhen City, China.

Postcode: 518028

Tel: (86-0755) 8335 3211 8335 6511

Fax: (86-0755) 8335 9011

Web Site: <http://www.fmsk.com/>