

Analog Multiplexers/Demultiplexers

The MC14051B, MC14052B, and MC14053B analog multiplexers are digitally-controlled analog switches. The MC14051B effectively implements an SP8T solid state switch, the MC14052B a DP4T, and the MC14053B a Triple SPDT. All three devices feature low ON impedance and very low OFF leakage current. Control of analog signals up to the complete supply voltage range can be achieved.

- Triple Diode Protection on Control Inputs
- Switch Function is Break Before Make
- Supply Voltage Range = 3.0 Vdc to 18 Vdc
- Analog Voltage Range ($V_{DD} - V_{EE}$) = 3.0 to 18 V
Note: V_{EE} must be $\leq V_{SS}$
- Linearized Transfer Characteristics
- Low-noise – 12 nV/ $\sqrt{\text{Cycle}}$, $f \geq 1.0$ kHz Typical
- Pin-for-Pin Replacement for CD4051, CD4052, and CD4053
- For 4PDT Switch, See MC14551B
- For Lower R_{ON} , Use the HC4051, HC4052, or HC4053 High-Speed CMOS Devices

MAXIMUM RATINGS*

Symbol	Parameter	Value	Unit
V_{DD}	DC Supply Voltage (Referenced to V_{EE} , $V_{SS} \geq V_{EE}$)	- 0.5 to + 18.0	V
V_{in}, V_{out}	Input or Output Voltage (DC or Transient) (Referenced to V_{SS} for Control Inputs and V_{EE} for Switch I/O)	- 0.5 to $V_{DD} + 0.5$	V
I_{in}	Input Current (DC or Transient), per Control Pin	± 10	mA
I_{sw}	Switch Through Current	± 25	mA
P_D	Power Dissipation, per Package†	500	mW
T_{stg}	Storage Temperature	- 65 to + 150	°C
T_L	Lead Temperature (8-Second Soldering)	260	°C

* Maximum Ratings are those values beyond which damage to the device may occur.
† Temperature Derating: "P and D/DW" Packages: - 7.0 mW/°C From 65°C To 125°C
Ceramic "L" Packages: - 12 mW/°C From 100°C To 125°C

MC14051B
8-Channel Analog Multiplexer/Demultiplexer

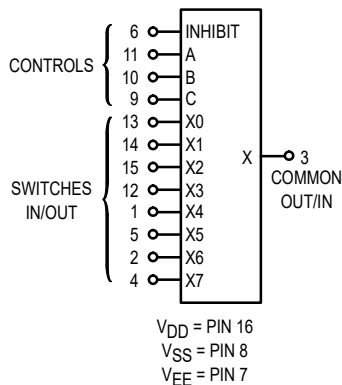

MC14052B
Dual 4-Channel Analog Multiplexer/Demultiplexer

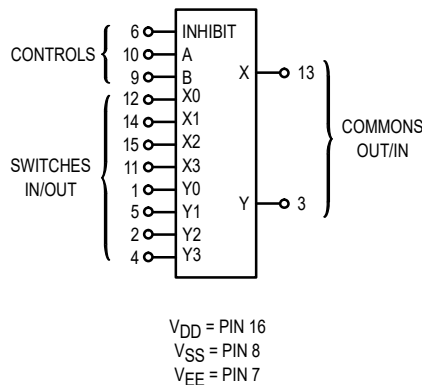

MC14051B MC14052B MC14053B

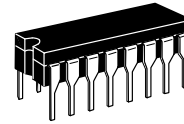

L SUFFIX
CERAMIC
CASE 620

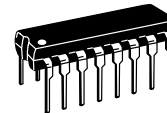

P SUFFIX
PLASTIC
CASE 648

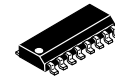

D SUFFIX
SOIC
CASE 751B

ORDERING INFORMATION

MC14XXXBCP Plastic
MC14XXXBCL Ceramic
MC14XXXBD SOIC
 $T_A = -55^\circ\text{C}$ to 125°C for all packages.

MC14053B
Triple 2-Channel Analog Multiplexer/Demultiplexer

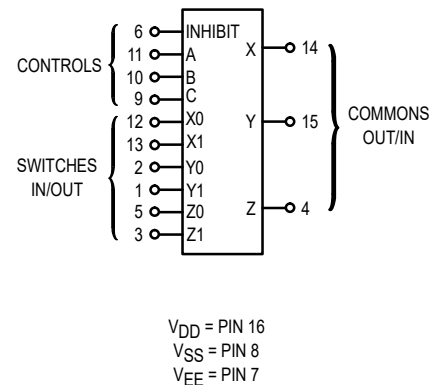

Note: Control Inputs referenced to V_{EE} . Analog Inputs and Outputs reference to V_{EE} . V_{EE} must be $< V_{SS}$.

ELECTRICAL CHARACTERISTICS

Characteristic	Symbol	V _{DD}	Test Conditions	- 55°C		25°C			125°C		Unit
				Min	Max	Min	Typ #	Max	Min	Max	

SUPPLY REQUIREMENTS (Voltages Referenced to V_{EE})

Power Supply Voltage Range	V _{DD}	—	V _{DD} - 3.0 ≥ V _{SS} ≥ V _{EE}	3.0	18	3.0	—	18	3.0	18	V
Quiescent Current Per Package	I _{DD}	5.0 10 15	Control Inputs: V _{in} = V _{SS} or V _{DD} , Switch I/O: V _{EE} ≤ V _{I/O} ≤ V _{DD} , and ΔV _{switch} ≤ 500 mV**	— — —	5.0 10 20	— — —	0.005 0.010 0.015	5.0 10 20	— — —	150 300 600	μA
Total Supply Current (Dynamic Plus Quiescent, Per Package)	I _{D(AV)}	5.0 10 15	T _A = 25°C only (The channel component, (V _{in} - V _{out})/R _{on} , is not included.)	Typical (0.07 μA/kHz) f + I _{DD} (0.20 μA/kHz) f + I _{DD} (0.36 μA/kHz) f + I _{DD}							μA

CONTROL INPUTS — INHIBIT, A, B, C (Voltages Referenced to V_{SS})

Low-Level Input Voltage	V _{IL}	5.0 10 15	R _{on} = per spec, I _{off} = per spec	— — —	1.5 3.0 4.0	— — —	2.25 4.50 6.75	1.5 3.0 4.0	— — —	1.5 3.0 4.0	V
High-Level Input Voltage	V _{IH}	5.0 10 15	R _{on} = per spec, I _{off} = per spec	3.5 7.0 11	— — —	3.5 7.0 11	2.75 5.50 8.25	— — —	3.5 7.0 11	— — —	V
Input Leakage Current	I _{in}	15	V _{in} = 0 or V _{DD}	—	± 0.1	—	± 0.00001	± 0.1	—	1.0	μA
Input Capacitance	C _{in}	—		—	—	—	5.0	7.5	—	—	pF

SWITCHES IN/OUT AND COMMONS OUT/IN — X, Y, Z (Voltages Referenced to V_{EE})

Recommended Peak-to-Peak Voltage Into or Out of the Switch	V _{I/O}	—	Channel On or Off	0	V _{DD}	0	—	V _{DD}	0	V _{DD}	V _{PP}
Recommended Static or Dynamic Voltage Across the Switch** (Figure 5)	ΔV _{switch}	—	Channel On	0	600	0	—	600	0	300	mV
Output Offset Voltage	V _{OO}	—	V _{in} = 0 V, No Load	—	—	—	10	—	—	—	μV
ON Resistance	R _{on}	5.0 10 15	ΔV _{switch} ≤ 500 mV**, V _{in} = V _{IL} or V _{IH} (Control), and V _{in} = 0 to V _{DD} (Switch)	— — —	800 400 220	— — —	250 120 80	1050 500 280	— — —	1200 520 300	Ω
ΔON Resistance Between Any Two Channels in the Same Package	ΔR _{on}	5.0 10 15		— — —	70 50 45	— — —	25 10 10	70 50 45	— — —	135 95 65	Ω
Off-Channel Leakage Current (Figure 10)	I _{off}	15	V _{in} = V _{IL} or V _{IH} (Control) Channel to Channel or Any One Channel	—	± 100	—	± 0.05	± 100	—	± 1000	nA
Capacitance, Switch I/O	C _{I/O}	—	Inhibit = V _{DD}	—	—	—	10	—	—	—	pF
Capacitance, Common O/I	C _{O/I}	—	Inhibit = V _{DD} (MC14051B) (MC14052B) (MC14053B)	— — —	— — —	— — —	60 32 17	— — —	— — —	— — —	pF
Capacitance, Feedthrough (Channel Off)	C _{I/O}	— —	Pins Not Adjacent Pins Adjacent	— —	— —	— —	0.15 0.47	— —	— —	— —	pF

#Data labeled "Typ" is not to be used for design purposes, but is intended as an indication of the IC's potential performance.

* For voltage drops across the switch (ΔV_{switch}) > 600 mV (> 300 mV at high temperature), excessive V_{DD} current may be drawn, i.e. the current out of the switch may contain both V_{DD} and switch input components. The reliability of the device will be unaffected unless the Maximum Ratings are exceeded. (See first page of this data sheet.)

ELECTRICAL CHARACTERISTICS* ($C_L = 50 \text{ pF}$, $T_A = 25^\circ\text{C}$) ($V_{EE} \leq V_{SS}$ unless otherwise indicated)

Characteristic	Symbol	$V_{DD} - V_{EE}$ Vdc	Typ # All Types	Max	Unit		
Propagation Delay Times (Figure 6) Switch Input to Switch Output ($R_L = 10 \text{ k}\Omega$) MC14051 $t_{PLH}, t_{PHL} = (0.17 \text{ ns/pF}) C_L + 26.5 \text{ ns}$ $t_{PLH}, t_{PHL} = (0.08 \text{ ns/pF}) C_L + 11 \text{ ns}$ $t_{PLH}, t_{PHL} = (0.06 \text{ ns/pF}) C_L + 9.0 \text{ ns}$ MC14052 $t_{PLH}, t_{PHL} = (0.17 \text{ ns/pF}) C_L + 21.5 \text{ ns}$ $t_{PLH}, t_{PHL} = (0.08 \text{ ns/pF}) C_L + 8.0 \text{ ns}$ $t_{PLH}, t_{PHL} = (0.06 \text{ ns/pF}) C_L + 7.0 \text{ ns}$ MC14053 $t_{PLH}, t_{PHL} = (0.17 \text{ ns/pF}) C_L + 16.5 \text{ ns}$ $t_{PLH}, t_{PHL} = (0.08 \text{ ns/pF}) C_L + 4.0 \text{ ns}$ $t_{PLH}, t_{PHL} = (0.06 \text{ ns/pF}) C_L + 3.0 \text{ ns}$	t_{PLH}, t_{PHL}	5.0	35	90	ns		
		10	15	40			
		15	12	30			
		Inhibit to Output ($R_L = 10 \text{ k}\Omega$, $V_{EE} = V_{SS}$) Output "1" or "0" to High Impedance, or High Impedance to "1" or "0" Level MC14051B	$t_{PHZ}, t_{PLZ},$ t_{PZH}, t_{PZL}	5.0	350	700	ns
				10	170	340	
				15	140	280	
		MC14052B		5.0	300	600	ns
				10	155	310	
				15	125	250	
		MC14053B		5.0	275	550	ns
				10	140	280	
				15	110	220	
Control Input to Output ($R_L = 10 \text{ k}\Omega$, $V_{EE} = V_{SS}$) MC14051B	t_{PLH}, t_{PHL}	5.0	360	720	ns		
		10	160	320			
		15	120	240			
		MC14052B		5.0	325	650	ns
				10	130	260	
				15	90	180	
		MC14053B		5.0	300	600	ns
				10	120	240	
				15	80	160	
Second Harmonic Distortion ($R_L = 10 \text{ k}\Omega$, $f = 1 \text{ kHz}$) $V_{in} = 5 V_{pp}$	—	10	0.07	—	%		
Bandwidth (Figure 7) ($R_L = 1 \text{ k}\Omega$, $V_{in} = 1/2 (V_{DD} - V_{EE})$ p-p, $C_L = 50 \text{ pF}$ $20 \text{ Log } (V_{out}/V_{in}) = -3 \text{ dB}$)	BW	10	17	—	MHz		
Off Channel Feedthrough Attenuation (Figure 7) $R_L = 1 \text{ k}\Omega$, $V_{in} = 1/2 (V_{DD} - V_{EE})$ p-p $f_{in} = 4.5 \text{ MHz}$ — MC14051B $f_{in} = 30 \text{ MHz}$ — MC14052B $f_{in} = 55 \text{ MHz}$ — MC14053B	—	10	-50	—	dB		
Channel Separation (Figure 8) ($R_L = 1 \text{ k}\Omega$, $V_{in} = 1/2 (V_{DD} - V_{EE})$ p-p, $f_{in} = 3.0 \text{ MHz}$)	—	10	-50	—	dB		
Crosstalk, Control Input to Common O/I (Figure 9) ($R_1 = 1 \text{ k}\Omega$, $R_L = 10 \text{ k}\Omega$ Control $t_{TLH} = t_{THL} = 20 \text{ ns}$, Inhibit = V_{SS})	—	10	75	—	mV		

* The formulas given are for the typical characteristics only at 25°C .

#Data labelled "Typ" is not to be used for design purposes but is intended as an indication of the IC's potential performance.

This device contains protection circuitry to guard against damage due to high static voltages or electric fields. However, precautions must be taken to avoid applications of any voltage higher than maximum rated voltages to this high-impedance circuit. For proper operation, V_{in} and V_{out} should be constrained to the range $V_{SS} \leq (V_{in} \text{ or } V_{out}) \leq V_{DD}$.

Unused inputs must always be tied to an appropriate logic voltage level (e.g., either V_{SS} , V_{EE} , or V_{DD}). Unused outputs must be left open.

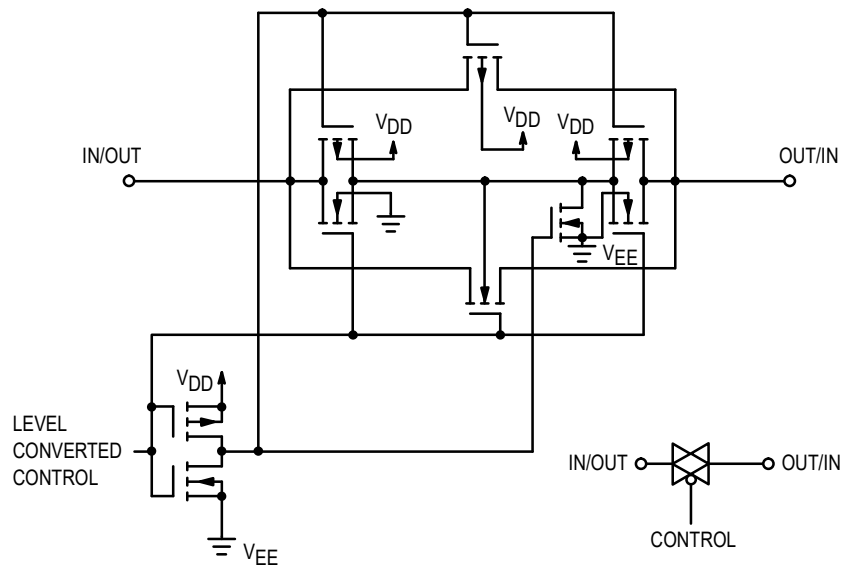

Figure 1. Switch Circuit Schematic

TRUTH TABLE

Control Inputs				ON Switches					
Inhibit	Select			MC14051B		MC14052B		MC14053B	
	C*	B	A	X0	Y0	X0	Z0	Y0	X0
0	0	0	0	X0	Y0	X0	Z0	Y0	X0
0	0	0	1	X1	Y1	X1	Z0	Y0	X1
0	0	1	0	X2	Y2	X2	Z0	Y1	X0
0	0	1	1	X3	Y3	X3	Z0	Y1	X1
0	1	0	0	X4			Z1	Y0	X0
0	1	0	1	X5			Z1	Y0	X1
0	1	1	0	X6			Z1	Y1	X0
0	1	1	1	X7			Z1	Y1	X1
1	x	x	x	None	None	None	None	None	None

* Not applicable for MC14052

x = Don't Care

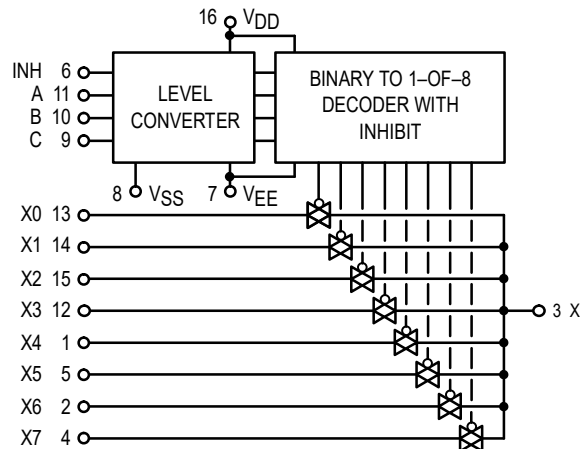

Figure 2. MC14051B Functional Diagram

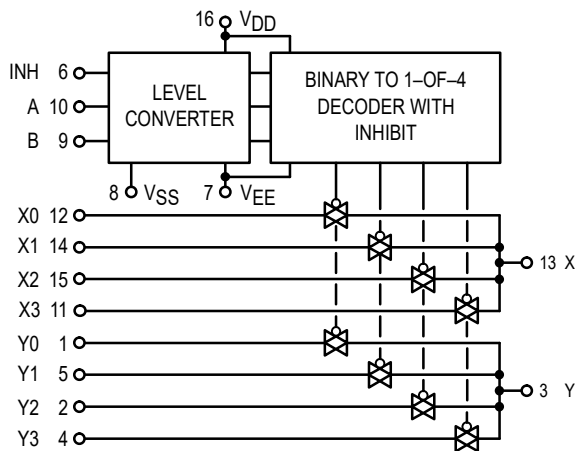

Figure 3. MC14052B Functional Diagram

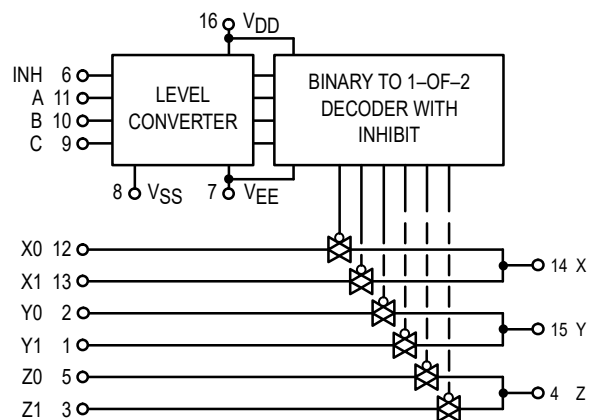

Figure 4. MC14053B Functional Diagram

TEST CIRCUITS

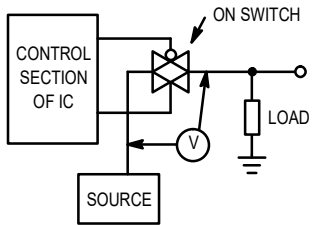

Figure 5. ΔV Across Switch

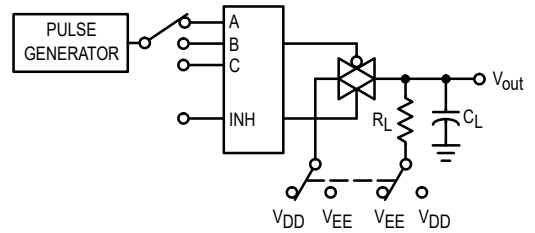

Figure 6. Propagation Delay Times, Control and Inhibit to Output

A, B, and C inputs used to turn ON or OFF the switch under test.

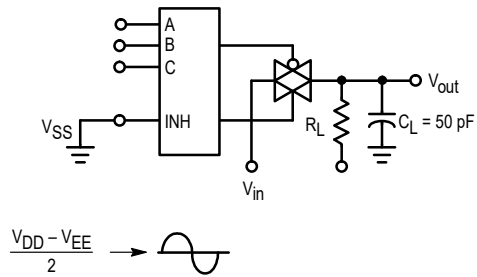

Figure 7. Bandwidth and Off-Channel Feedthrough Attenuation

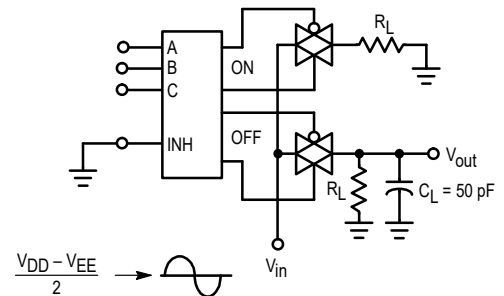

Figure 8. Channel Separation (Adjacent Channels Used For Setup)

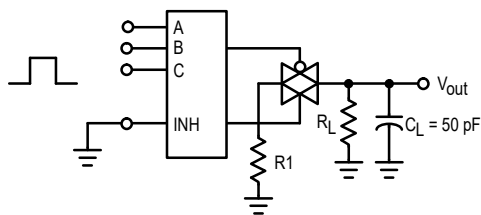

Figure 9. Crosstalk, Control Input to Common O/I

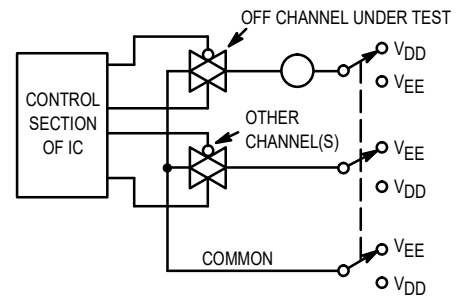

Figure 10. Off Channel Leakage

NOTE: See also Figures 7 and 8 on Page 6-51.

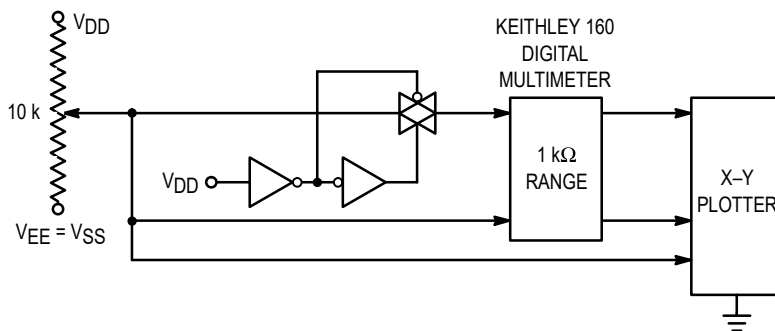

Figure 11. Channel Resistance (R_{ON}) Test Circuit

TYPICAL RESISTANCE CHARACTERISTICS

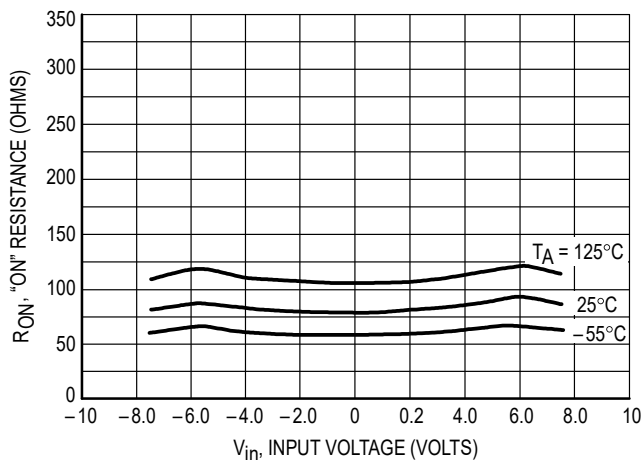

Figure 12. $V_{DD} = 7.5\text{ V}$, $V_{EE} = -7.5\text{ V}$

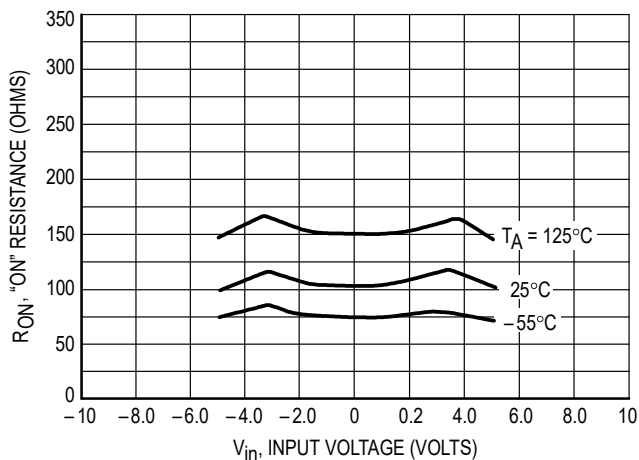

Figure 13. $V_{DD} = 5.0\text{ V}$, $V_{EE} = -5.0\text{ V}$

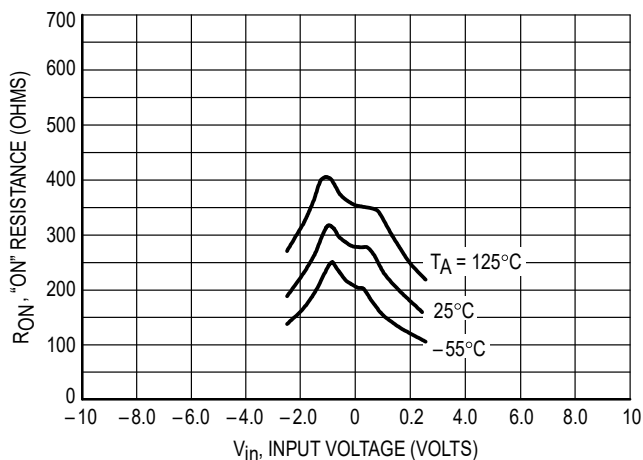

Figure 14. $V_{DD} = 2.5\text{ V}$, $V_{EE} = -2.5\text{ V}$

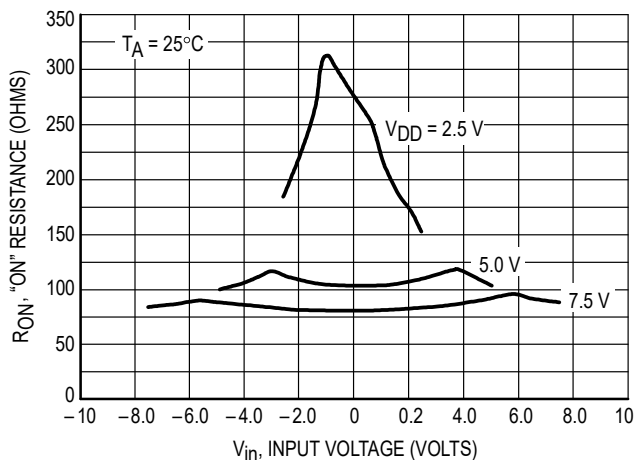
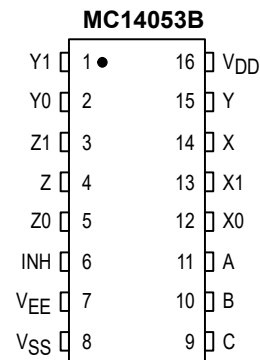
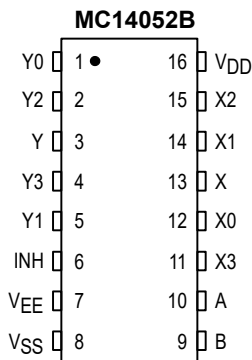
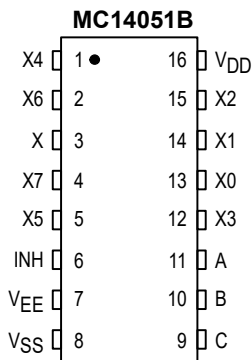

Figure 15. Comparison at 25°C , $V_{DD} = -V_{EE}$

PIN ASSIGNMENT



APPLICATIONS INFORMATION

Figure A illustrates use of the on-chip level converter detailed in Figures 2, 3, and 4. The 0-to-5 V Digital Control signal is used to directly control a 9 V_{p-p} analog signal.

The digital control logic levels are determined by V_{DD} and V_{SS}. The V_{DD} voltage is the logic high voltage; the V_{SS} voltage is logic low. For the example, V_{DD} = +5 V = logic high at the control inputs; V_{SS} = GND = 0 V = logic low.

The maximum analog signal level is determined by V_{DD} and V_{EE}. The V_{DD} voltage determines the maximum recommended peak above V_{SS}. The V_{EE} voltage determines the maximum swing below V_{SS}. For the example, V_{DD} - V_{SS} = 5 V maximum swing above V_{SS}; V_{SS} - V_{EE} = 5 V maximum swing below V_{SS}. The example shows a ± 4.5 V signal which allows a 1/2 volt margin at each peak. If voltage transients

above V_{DD} and/or below V_{EE} are anticipated on the analog channels, external diodes (D_x) are recommended as shown in Figure B. These diodes should be small signal types able to absorb the maximum anticipated current surges during clipping.

The *absolute* maximum potential difference between V_{DD} and V_{EE} is 18.0 V. Most parameters are specified up to 15 V which is the *recommended* maximum difference between V_{DD} and V_{EE}.

Balanced supplies are not required. However, V_{SS} must be greater than or equal to V_{EE}. For example, V_{DD} = +10 V, V_{SS} = +5 V, and V_{EE} = -3 V is acceptable. See the Table below.

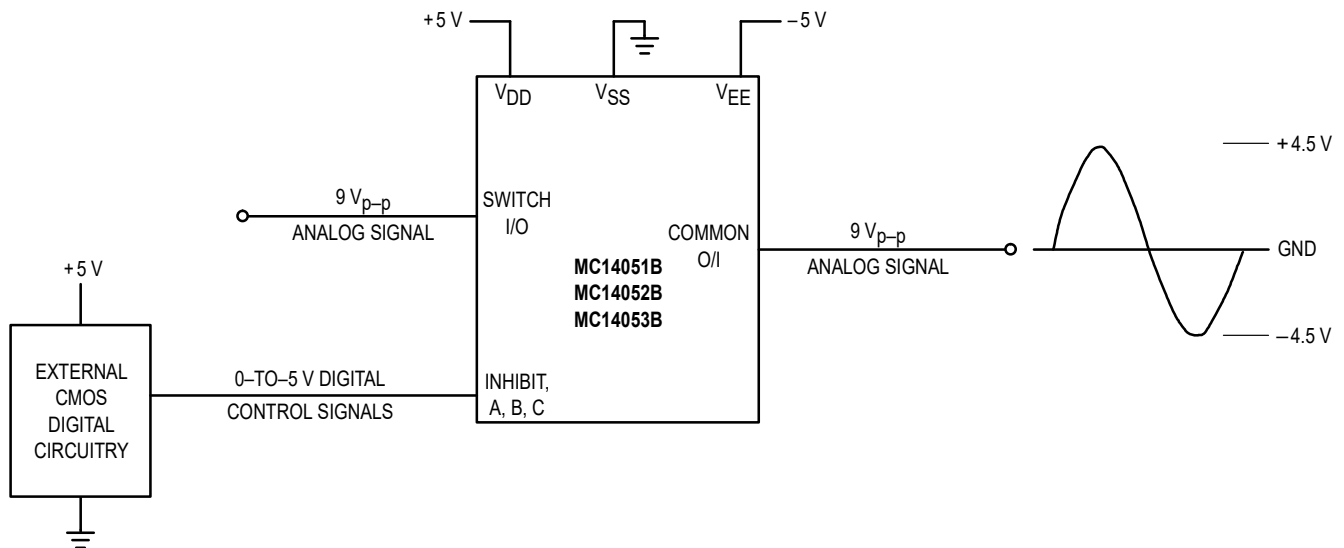

Figure A. Application Example

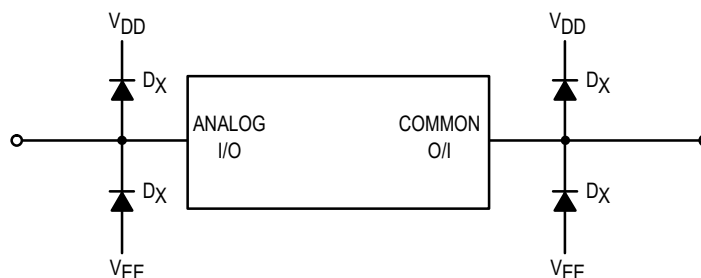

Figure B. External Germanium or Schottky Clipping Diodes

POSSIBLE SUPPLY CONNECTIONS

V _{DD} In Volts	V _{SS} In Volts	V _{EE} In Volts	Control Inputs Logic High/Logic Low In Volts	Maximum Analog Signal Range In Volts
+ 8	0	- 8	+ 8/0	+ 8 to - 8 = 16 V _{p-p}
+ 5	0	- 12	+ 5/0	+ 5 to - 12 = 17 V _{p-p}
+ 5	0	0	+ 5/0	+ 5 to 0 = 5 V _{p-p}
+ 5	0	- 5	+ 5/0	+ 5 to - 5 = 10 V _{p-p}
+ 10	+ 5	- 5	+ 10/+ 5	+ 10 to - 5 = 15 V _{p-p}

OUTLINE DIMENSIONS

L SUFFIX CERAMIC DIP PACKAGE CASE 620-10 ISSUE V

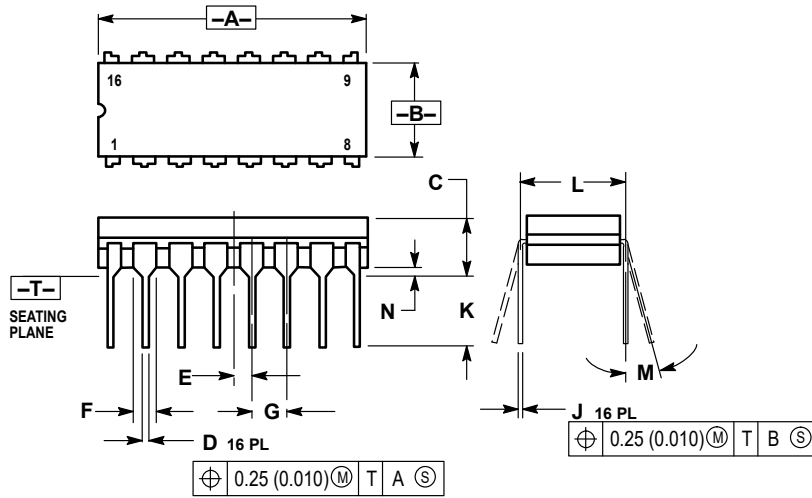

NOTES:

1. DIMENSIONING AND TOLERANCING PER ANSI Y14.5M, 1982.
2. CONTROLLING DIMENSION: INCH.
3. DIMENSION L TO CENTER OF LEAD WHEN FORMED PARALLEL.
4. DIMENSION F MAY NARROW TO 0.76 (0.030) WHERE THE LEAD ENTERS THE CERAMIC BODY.

DIM	INCHES		MILLIMETERS	
	MIN	MAX	MIN	MAX
A	0.750	0.785	19.05	19.93
B	0.240	0.295	6.10	7.49
C	—	0.200	—	5.08
D	0.015	0.020	0.39	0.50
E	0.050 BSC		1.27 BSC	
F	0.055	0.065	1.40	1.65
G	0.100 BSC		2.54 BSC	
H	0.008	0.015	0.21	0.38
K	0.125	0.170	3.18	4.31
L	0.300 BSC		7.62 BSC	
M	0°	15°	0°	15°
N	0.020	0.040	0.51	1.01

P SUFFIX PLASTIC DIP PACKAGE CASE 648-08 ISSUE R

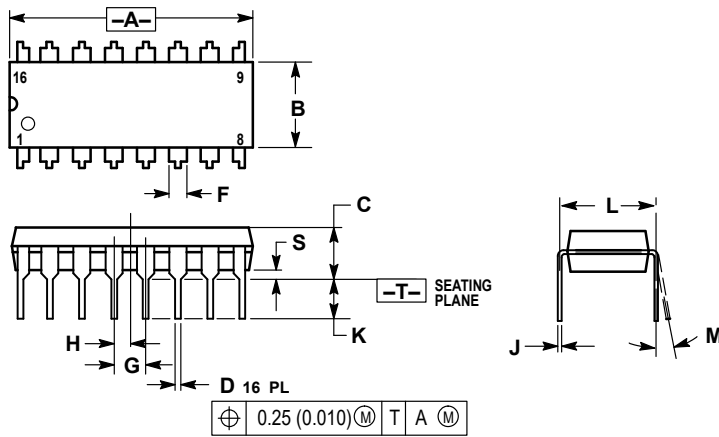

NOTES:

1. DIMENSIONING AND TOLERANCING PER ANSI Y14.5M, 1982.
2. CONTROLLING DIMENSION: INCH.
3. DIMENSION L TO CENTER OF LEADS WHEN FORMED PARALLEL.
4. DIMENSION B DOES NOT INCLUDE MOLD FLASH.
5. ROUNDED CORNERS OPTIONAL.

DIM	INCHES		MILLIMETERS	
	MIN	MAX	MIN	MAX
A	0.740	0.770	18.80	19.55
B	0.250	0.270	6.35	6.85
C	0.145	0.175	3.69	4.44
D	0.015	0.021	0.39	0.53
F	0.040	0.70	1.02	1.77
G	0.100 BSC		2.54 BSC	
H	0.050 BSC		1.27 BSC	
J	0.008	0.015	0.21	0.38
K	0.110	0.130	2.80	3.30
L	0.295	0.305	7.50	7.74
M	0°	10°	0°	10°
S	0.020	0.040	0.51	1.01

OUTLINE DIMENSIONS

D SUFFIX PLASTIC SOIC PACKAGE CASE 751B-05 ISSUE J

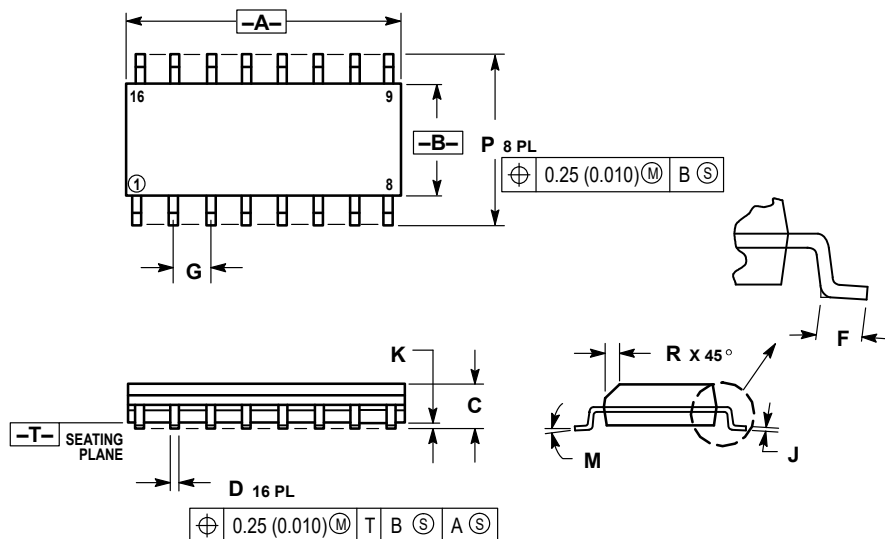

NOTES:

1. DIMENSIONING AND TOLERANCING PER ANSI Y14.5M, 1982.
2. CONTROLLING DIMENSION: MILLIMETER.
3. DIMENSIONS A AND B DO NOT INCLUDE MOLD PROTRUSION.
4. MAXIMUM MOLD PROTRUSION 0.15 (0.006) PER SIDE.
5. DIMENSION D DOES NOT INCLUDE DAMBAR PROTRUSION. ALLOWABLE DAMBAR PROTRUSION SHALL BE 0.127 (0.005) TOTAL IN EXCESS OF THE D DIMENSION AT MAXIMUM MATERIAL CONDITION.

DIM	MILLIMETERS		INCHES	
	MIN	MAX	MIN	MAX
A	9.80	10.00	0.386	0.393
B	3.80	4.00	0.150	0.157
C	1.35	1.75	0.054	0.068
D	0.35	0.49	0.014	0.019
F	0.40	1.25	0.016	0.049
G	1.27 BSC		0.050 BSC	
J	0.19	0.25	0.008	0.009
K	0.10	0.25	0.004	0.009
M	0°	7°	0°	7°
P	5.80	6.20	0.229	0.244
R	0.25	0.50	0.010	0.019

Motorola reserves the right to make changes without further notice to any products herein. Motorola makes no warranty, representation or guarantee regarding the suitability of its products for any particular purpose, nor does Motorola assume any liability arising out of the application or use of any product or circuit, and specifically disclaims any and all liability, including without limitation consequential or incidental damages. "Typical" parameters which may be provided in Motorola data sheets and/or specifications can and do vary in different applications and actual performance may vary over time. All operating parameters, including "Typicals" must be validated for each customer application by customer's technical experts. Motorola does not convey any license under its patent rights nor the rights of others. Motorola products are not designed, intended, or authorized for use as components in systems intended for surgical implant into the body, or other applications intended to support or sustain life, or for any other application in which the failure of the Motorola product could create a situation where personal injury or death may occur. Should Buyer purchase or use Motorola products for any such unintended or unauthorized application, Buyer shall indemnify and hold Motorola and its officers, employees, subsidiaries, affiliates, and distributors harmless against all claims, costs, damages, and expenses, and reasonable attorney fees arising out of, directly or indirectly, any claim of personal injury or death associated with such unintended or unauthorized use, even if such claim alleges that Motorola was negligent regarding the design or manufacture of the part. Motorola and are registered trademarks of Motorola, Inc. Motorola, Inc. is an Equal Opportunity/Affirmative Action Employer.

How to reach us:

USA/EUROPE/Locations Not Listed: Motorola Literature Distribution;
P.O. Box 20912; Phoenix, Arizona 85036. 1-800-441-2447 or 602-303-5454

JAPAN: Nippon Motorola Ltd.; Tatsumi-SPD-JLDC, 6F Seibu-Butsuryu-Center,
3-14-2 Tatsumi Koto-Ku, Tokyo 135, Japan. 03-81-3521-8315

MFAX: RMFAX0@email.sps.mot.com - TOUCHTONE 602-244-6609
INTERNET: <http://Design-NET.com>

ASIA/PACIFIC: Motorola Semiconductors H.K. Ltd.; 8B Tai Ping Industrial Park,
51 Ting Kok Road, Tai Po, N.T., Hong Kong. 852-26629298



MC14051B/D

