

Descriptions

The S78xx series are three-terminal positive regulators providing over 1A output current with internal current limiting, thermal shutdown and safe area protection. These regulators are useful in a wide range of applications. Although they are just fixed voltage regulators, the S78xx series can be used with external components to obtain adjustable voltages and currents.

Features

- Internal Short Circuit Current Limiting
- Maximum Output Current (1A Max.)
- Thermal Overload Protection
- Output Transistor Safe Area Protection

Ordering Information

Type NO.	Marking	Package Code
S78xxPI	S78□□PI	TO-220F

□□:Voltage Code (05:5V, 06:6V, 08:8V, 09:9V, 10:10V,12:12V,15:15V,24:24V)

Outline Dimensions

unit : mm

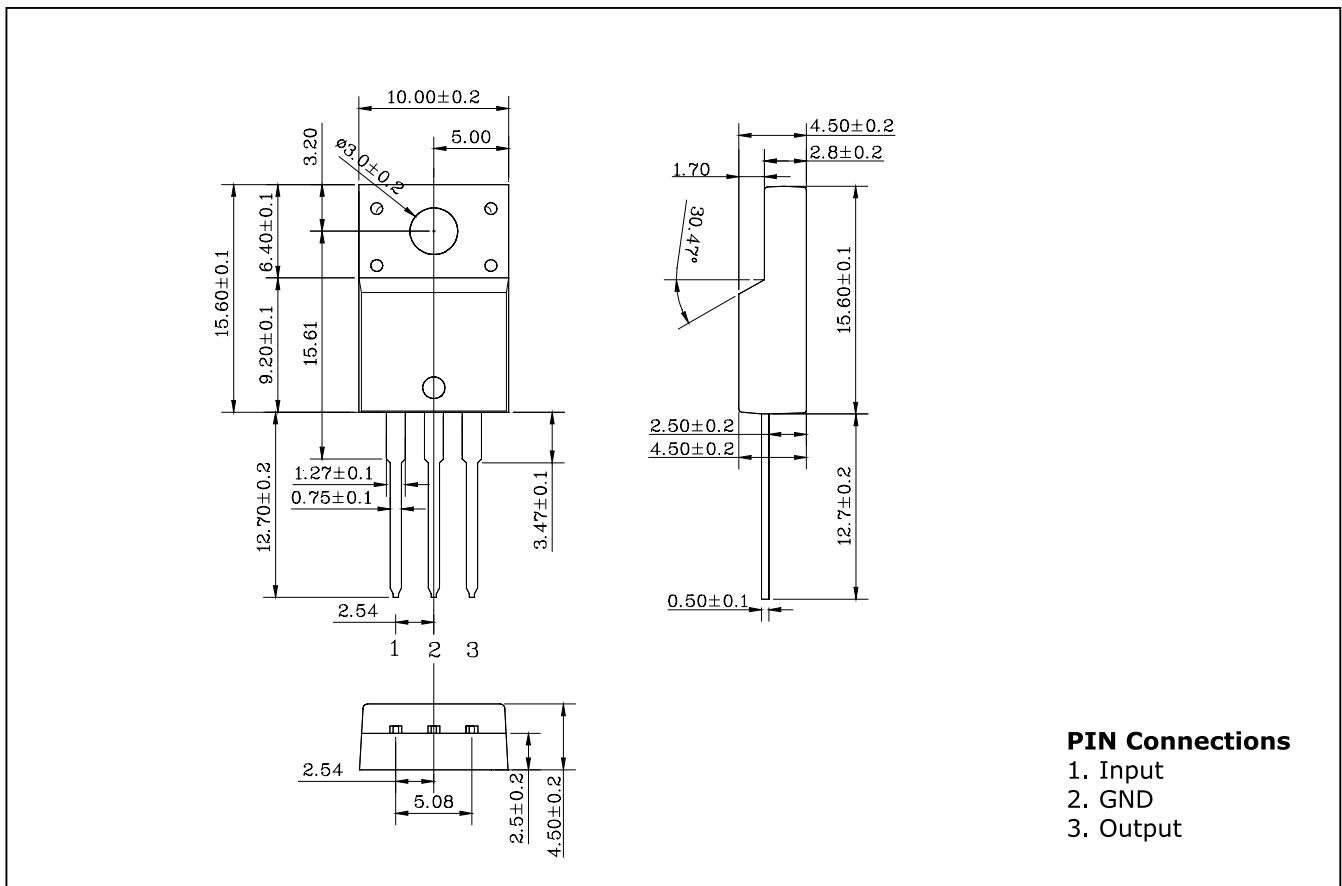

Absolute Maximum Ratings

Ta=25°C

Characteristic	Symbol	Ratings	Unit
Operating Input voltage	V _{IN}	40 (S7824PI)	V
		35 (ALL Others)	V
Power Dissipation (T _C =25°C)	P _D	20.8	W
Power Dissipation (without Heatsink)	P _D	2.0	W
Operating Junction Temperature	T _J	-30 ~ 125	°C
Storage Temperature	T _{stg}	-55 ~ 150	°C

Electrical Characteristics

(V_{IN} = 10V, I_{OUT} = 500mA, T_J = 0°C ~ 125°C, Unless otherwise noted)

Characteristic	Symbol	Test Condition	S7805PI			Unit	
			Min.	Typ.	Max.		
Output Voltage	V _{OUT}	T _J = 25°C	4.8	5.0	5.2	V	
		I _{OUT} = 5mA ~ 1A V _{IN} = 7.0V ~ 20V, P _O ≤ 15W	4.75	5.0	5.25		
Line Regulation	ΔV _{OUT}	V _{IN} = 7.0V ~ 25V	-	3	100	mV	
		V _{IN} = 8.0V ~ 12V	-	1	50		
Load Regulation	ΔV _{OUT}	I _{OUT} = 5mA ~ 1.5A	-	15	100	mV	
		I _{OUT} = 250mA ~ 750mA	-	5	50		
Quiescent Current	I _B	T _J = 25°C	-	4.2	8.0	mA	
Quiescent Current Change	ΔI _B	V _{IN} = 7.0V ~ 25V	-	-	1.3	mA	
		I _{OUT} = 5mA ~ 1A	-	-	0.5		
Output Noise Voltage	V _N	f = 10Hz ~ 100KHz	T _J = 25°C	-	40	-	uV _{rms}
Ripple Rejection Ratio	RR	f = 120Hz, V _{IN} = 8.0V ~ 18V		62	78	-	dB
Dropout Voltage	V _D	I _{OUT} = 1A	T _J = 25°C	-	2.0	-	V
Short Circuit Current Limit	I _{SC}		T _J = 25°C	-	0.75	-	A
Output Voltage Drift	TC _{VO}	I _{OUT} = 5mA	T _J = 25°C	-	-1.1	-	mV/°C
Peak Output Current	I _{PK}		T _J = 25°C	-	2.2	-	A

* Pulse testing techniques are used to maintain the junction temperature as close to the ambient temperature as possible. Thermal effects must be taken into separately.

Electrical Characteristics

($V_{IN} = 11V$, $I_{OUT} = 500mA$, $T_j = 0^\circ C \sim 125^\circ C$, Unless otherwise noted)

Characteristic	Symbol	Test Condition		S7806PI			Unit
				Min.	Typ.	Max.	
Output Voltage	V_{OUT}		$T_j = 25^\circ C$	5.75	6.0	6.25	V
		$I_{OUT} = 5mA \sim 1A$ $V_{IN} = 8.0V \sim 21V$, $P_O \leq 15W$		5.7	6.0	6.3	
Line Regulation	ΔV_{OUT}	$V_{IN} = 8.0V \sim 25V$	$T_j = 25^\circ C$	-	5	120	mV
		$V_{IN} = 9.0V \sim 13V$		-	1.5	60	
Load Regulation	ΔV_{OUT}	$I_{OUT} = 5mA \sim 1.5A$	$T_j = 25^\circ C$	-	14	120	mV
		$I_{OUT} = 250mA \sim 750mA$		-	4	60	
Quiescent Current	I_B		$T_j = 25^\circ C$	-	4.3	8.0	mA
Quiescent Current Change	ΔI_B	$V_{IN} = 8.0V \sim 25V$		-	-	1.3	mA
		$I_{OUT} = 5mA \sim 1A$		-	-	0.5	
Output Noise Voltage	V_N	$f = 10Hz \sim 100KHz$	$T_j = 25^\circ C$	-	45	-	μV_{rms}
Ripple Rejection Ratio	RR	$f = 120Hz$, $V_{IN} = 9.0V \sim 19V$		59	75	-	dB
Dropout Voltage	V_D	$I_{OUT} = 1A$	$T_j = 25^\circ C$	-	2.0	-	V
Short Circuit Current Limit	I_{SC}		$T_j = 25^\circ C$	-	0.55	-	A
Output Voltage Drift	TC_{VO}	$I_{OUT} = 5mA$	$T_j = 25^\circ C$	-	-0.8	-	$mV/^\circ C$
Peak Output Current	I_{PK}		$T_j = 25^\circ C$	-	2.2	-	A

* Pulse testing techniques are used to maintain the junction temperature as close to the ambient temperature as possible. Thermal effects must be taken into separately.

Electrical Characteristics

($V_{IN} = 14V$, $I_{OUT} = 500mA$, $T_j = 0^{\circ}C \sim 125^{\circ}C$, Unless otherwise noted)

Characteristic	Symbol	Test Condition		S7808PI			Unit
				Min.	Typ.	Max.	
Output Voltage	V_{OUT}		$T_j = 25^{\circ}C$	7.7	8.0	8.3	V
		$I_{OUT} = 5mA \sim 1A$ $V_{IN} = 10.5V \sim 23V$, $P_O \leq 15W$		7.6	8.0	8.4	
Line Regulation	ΔV_{OUT}	$V_{IN} = 10.5V \sim 25V$	$T_j = 25^{\circ}C$	-	6	160	mV
		$V_{IN} = 11.0V \sim 17V$		-	2	80	
Load Regulation	ΔV_{OUT}	$I_{OUT} = 5mA \sim 1.5A$	$T_j = 25^{\circ}C$	-	12	160	mV
		$I_{OUT} = 250mA \sim 750mA$		-	4	80	
Quiescent Current	I_B		$T_j = 25^{\circ}C$	-	4.3	8.0	mA
Quiescent Current Change	ΔI_B	$V_{IN} = 10.5V \sim 25V$		-	-	1.0	mA
		$I_{OUT} = 5mA \sim 1A$		-	-	0.5	
Output Noise Voltage	V_N	$f = 10Hz \sim 100KHz$	$T_j = 25^{\circ}C$	-	52	-	μV_{rms}
Ripple Rejection Ratio	RR	$f = 120Hz$, $V_{IN} = 11.5V \sim 21.5V$		55	72	-	dB
Dropout Voltage	V_D	$I_{OUT} = 1A$	$T_j = 25^{\circ}C$	-	2.0	-	V
Short Circuit Current Limit	I_{SC}		$T_j = 25^{\circ}C$	-	0.45	-	A
Output Voltage Drift	TC_{VO}	$I_{OUT} = 5mA$	$T_j = 25^{\circ}C$	-	-0.8	-	$mV/^{\circ}C$
Peak Output Current	I_{PK}		$T_j = 25^{\circ}C$	-	2.2	-	A

* Pulse testing techniques are used to maintain the junction temperature as close to the ambient temperature as possible. Thermal effects must be taken into separately.

Electrical Characteristics

($V_{IN} = 16V$, $I_{OUT} = 500mA$, $T_j = 0^\circ C \sim 125^\circ C$, Unless otherwise noted)

Characteristic	Symbol	Test Condition		S7809PI			Unit
				Min.	Typ.	Max.	
Output Voltage	V_{OUT}		$T_j = 25^\circ C$	8.65	9.0	9.35	V
		$I_{OUT} = 5mA \sim 1A$ $V_{IN} = 11.5V \sim 24V$, $P_o \leq 15W$		8.55	9.0	9.45	
Line Regulation	ΔV_{OUT}	$V_{IN} = 11.5V \sim 27V$	$T_j = 25^\circ C$	-	7	180	mV
		$V_{IN} = 13.0V \sim 19V$		-	2	90	
Load Regulation	ΔV_{OUT}	$I_{OUT} = 5mA \sim 1.5A$	$T_j = 25^\circ C$	-	12	180	mV
		$I_{OUT} = 250mA \sim 750mA$		-	4	90	
Quiescent Current	I_B		$T_j = 25^\circ C$	-	4.3	8.0	mA
Quiescent Current Change	ΔI_B	$V_{IN} = 11.5V \sim 27V$		-	-	1.0	mA
		$I_{OUT} = 5mA \sim 1A$		-	-	0.5	
Output Noise Voltage	V_N	$f = 10Hz \sim 100KHz$,	$T_j = 25^\circ C$	-	60	-	μV_{rms}
Ripple Rejection Ratio	RR	$f = 120Hz$, $V_{IN} = 12V \sim 22V$		55	70	-	dB
Dropout Voltage	V_D	$I_{OUT} = 1A$	$T_j = 25^\circ C$	-	2.0	-	V
Short Circuit Current Limit	I_{SC}		$T_j = 25^\circ C$	-	0.4	-	A
Output Voltage Drift	TC_{VO}	$I_{OUT} = 5mA$	$T_j = 25^\circ C$	-	-1.0	-	$mV/^\circ C$
Peak Output Current	I_{PK}		$T_j = 25^\circ C$	-	2.2	-	A

* Pulse testing techniques are used to maintain the junction temperature as close to the ambient temperature as possible. Thermal effects must be taken into separately.

]

Electrical Characteristics

($V_{IN} = 17V$, $I_{OUT} = 500mA$, $T_j = 0^{\circ}C \sim 125^{\circ}C$, Unless otherwise noted)

Characteristic	Symbol	Test Condition		S7810PI			Unit
				Min.	Typ.	Max.	
Output Voltage	V_{OUT}		$T_j = 25^{\circ}C$	9.6	10.0	10.4	V
		$I_{OUT} = 5mA \sim 1A$ $V_{IN} = 12.5V \sim 25V$, $P_O \leq 15W$		9.5	10.0	10.5	
Line Regulation	ΔV_{OUT}	$V_{IN} = 12.5V \sim 28V$	$T_j = 25^{\circ}C$	-	7	200	mV
		$V_{IN} = 14.0V \sim 20V$		-	2	100	
Load Regulation	ΔV_{OUT}	$I_{OUT} = 5mA \sim 1.5A$	$T_j = 25^{\circ}C$	-	12	200	mV
		$I_{OUT} = 250mA \sim 750mA$		-	4	100	
Quiescent Current	I_B		$T_j = 25^{\circ}C$	-	4.3	8.0	mA
Quiescent Current Change	ΔI_B	$V_{IN} = 12.5V \sim 28V$		-	-	1.0	mA
		$I_{OUT} = 5mA \sim 1A$		-	-	0.5	
Output Noise Voltage	V_N	$f = 10Hz \sim 100KHz$,	$T_j = 25^{\circ}C$	-	70	-	μV_{rms}
Ripple Rejection Ratio	RR	$f = 120Hz$, $V_{IN} = 13V \sim 23V$		55	71	-	dB
Dropout Voltage	V_D	$I_{OUT} = 1A$	$T_j = 25^{\circ}C$	-	2.0	-	V
Short Circuit Current Limit	I_{SC}		$T_j = 25^{\circ}C$	-	0.4	-	A
Output Voltage Drift	TC_{VO}	$I_{OUT} = 5mA$	$T_j = 25^{\circ}C$	-	-1.0	-	$mV/^{\circ}C$
Peak Output Current	I_{PK}		$T_j = 25^{\circ}C$	-	2.2	-	A

* Pulse testing techniques are used to maintain the junction temperature as close to the ambient temperature as possible. Thermal effects must be taken into separately.

Electrical Characteristics

($V_{IN} = 19V$, $I_{OUT} = 500mA$, $T_j = 0^\circ C \sim 125^\circ C$, Unless otherwise noted)

Characteristic	Symbol	Test Condition		S7812PI			Unit
				Min.	Typ.	Max.	
Output Voltage	V_{OUT}		$T_j = 25^\circ C$	11.5	12.0	12.5	V
		$I_{OUT} = 5mA \sim 1A$ $V_{IN} = 14.5V \sim 30V$, $P_o \leq 15W$		11.4	12.0	12.6	
Line Regulation	ΔV_{OUT}	$V_{IN} = 14.5V \sim 30V$	$T_j = 25^\circ C$	-	10	240	mV
		$V_{IN} = 16.0V \sim 22V$		-	3	120	
Load Regulation	ΔV_{OUT}	$I_{OUT} = 5mA \sim 1.5A$	$T_j = 25^\circ C$	-	12	240	mV
		$I_{OUT} = 250mA \sim 750mA$		-	4	120	
Quiescent Current	I_B		$T_j = 25^\circ C$	-	4.3	8.0	mA
Quiescent Current Change	ΔI_B	$V_{IN} = 14.5V \sim 30V$		-	-	1.0	mA
		$I_{OUT} = 5mA \sim 1A$		-	-	0.5	
Output Noise Voltage	V_N	$f = 10Hz \sim 100KHz$,	$T_j = 25^\circ C$	-	75	-	μV_{rms}
Ripple Rejection Ratio	RR	$f = 120Hz$, $V_{IN} = 15V \sim 25V$		55	71	-	dB
Dropout Voltage	V_D	$I_{OUT} = 1A$	$T_j = 25^\circ C$	-	2.0	-	V
Short Circuit Current Limit	I_{SC}		$T_j = 25^\circ C$	-	0.35	-	A
Output Voltage Drift	TC_{VO}	$I_{OUT} = 5mA$	$T_j = 25^\circ C$	-	-1.0	-	$mV/^\circ C$
Peak Output Current	I_{PK}		$T_j = 25^\circ C$	-	2.2	-	A

* Pulse testing techniques are used to maintain the junction temperature as close to the ambient temperature as possible. Thermal effects must be taken into separately.

Electrical Characteristics

($V_{IN}=23V$, $I_{OUT}=500mA$, $T_j = 0^{\circ}C \sim 125^{\circ}C$, Unless otherwise noted)

Characteristic	Symbol	Test Condition		S7815PI			Unit
				Min.	Typ.	Max.	
Output Voltage	V_{OUT}		$T_j = 25^{\circ}C$	14.4	15.0	15.6	V
		$I_{OUT}=5mA \sim 1A$ $V_{IN}=17.5V \sim 30V, P_o \leq 15W$		14.25	15.0	15.75	
Line Regulation	ΔV_{OUT}	$V_{IN}=17.5V \sim 30V$	$T_j = 25^{\circ}C$	-	12	300	mV
		$V_{IN}=20V \sim 26V$		-	3	150	
Load Regulation	ΔV_{OUT}	$I_{OUT}=5mA \sim 1.5A$	$T_j = 25^{\circ}C$	-	12	300	mV
		$I_{OUT}=250mA \sim 750mA$		-	4	150	
Quiescent Current	I_B		$T_j = 25^{\circ}C$	-	4.3	8.0	mA
Quiescent Current Change	ΔI_B	$V_{IN} = 17.5V \sim 30V$		-	-	1.0	mA
		$I_{OUT} = 5mA \sim 1A$		-	-	0.5	
Output Noise Voltage	V_N	$f=10Hz \sim 100KHz,$	$T_j = 25^{\circ}C$	-	90	-	μV_{rms}
Ripple Rejection Ratio	RR	$f=120Hz, V_{IN} = 18.5V \sim 28.5V$		54	70	-	dB
Dropout Voltage	V_D	$I_{OUT}=1A$	$T_j = 25^{\circ}C$	-	2.0	-	V
Short Circuit Current Limit	I_{SC}		$T_j = 25^{\circ}C$	-	0.23	-	A
Output Voltage Drift	TC_{VO}	$I_{OUT}=5mA$	$T_j = 25^{\circ}C$	-	-1.0	-	$mV/^{\circ}C$
Peak Output Current	I_{PK}		$T_j = 25^{\circ}C$	-	2.1	-	A

* Pulse testing techniques are used to maintain the junction temperature as close to the ambient temperature as possible. Thermal effects must be taken into separately.

Electrical Characteristics

($V_{IN} = 33V$, $I_{OUT} = 500mA$, $T_j = 0^\circ C \sim 125^\circ C$, Unless otherwise noted)

Characteristic	Symbol	Test Condition		S7824PI			Unit
				Min.	Typ.	Max.	
Output Voltage	V_{OUT}		$T_j = 25^\circ C$	23.0	24.0	25.0	V
		$I_{OUT} = 5mA \sim 1A$ $V_{IN} = 27V \sim 38V, P_O \leq 15W$		22.8	24.0	25.2	
Line Regulation	ΔV_{OUT}	$V_{IN} = 27V \sim 38V$	$T_j = 25^\circ C$	-	18	480	mV
		$V_{IN} = 30V \sim 36V$		-	6	240	
Load Regulation	ΔV_{OUT}	$I_{OUT} = 5mA \sim 1.5A$	$T_j = 25^\circ C$	-	12	480	mV
		$I_{OUT} = 250mA \sim 750mA$		-	4	240	
Quiescent Current	I_B		$T_j = 25^\circ C$	-	4.6	8.0	mA
Quiescent Current Change	ΔI_B	$V_{IN} = 27V \sim 38V$		-	-	1.0	mA
		$I_{OUT} = 5mA \sim 1A$		-	-	0.5	
Output Noise Voltage	V_N	$f = 10Hz \sim 100KHz,$	$T_j = 25^\circ C$	-	170	-	μV_{rms}
Ripple Rejection Ratio	RR	$f = 120Hz, V_{IN} = 28V \sim 38V$		50	66	-	dB
Dropout Voltage	V_D	$I_{OUT} = 1A$	$T_j = 25^\circ C$	-	2.0	-	V
Short Circuit Current Limit	I_{SC}		$T_j = 25^\circ C$	-	0.15	-	A
Output Voltage Drift	TC_{VO}	$I_{OUT} = 5mA$	$T_j = 25^\circ C$	-	-1.5	-	$mV/^\circ C$
Peak Output Current	I_{PK}		$T_j = 25^\circ C$	-	2.1	-	A

* Pulse testing techniques are used to maintain the junction temperature as close to the ambient temperature as possible. Thermal effects must be taken into separately.

Test circuit

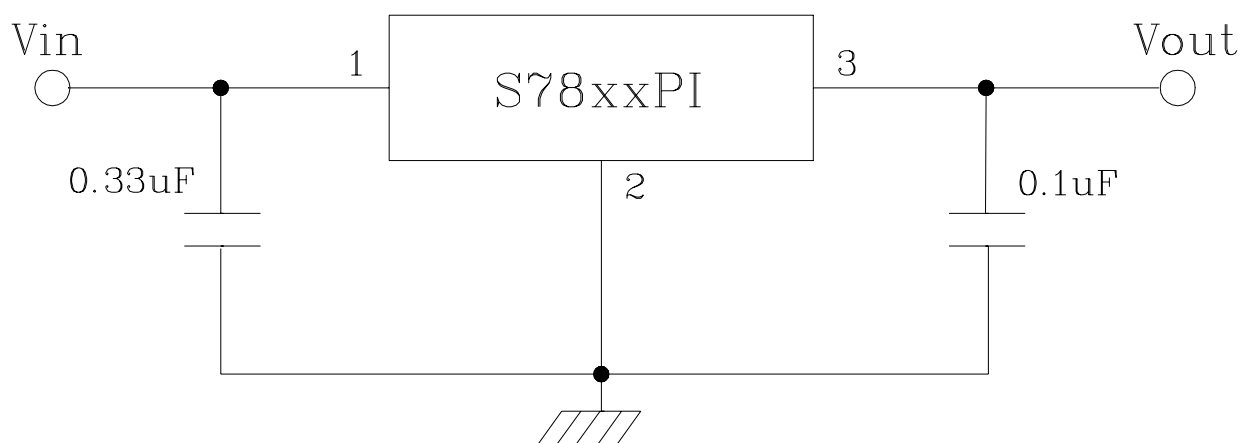

Electrical Characteristic Curves

Fig. 1 V_{DVS} vs T_j

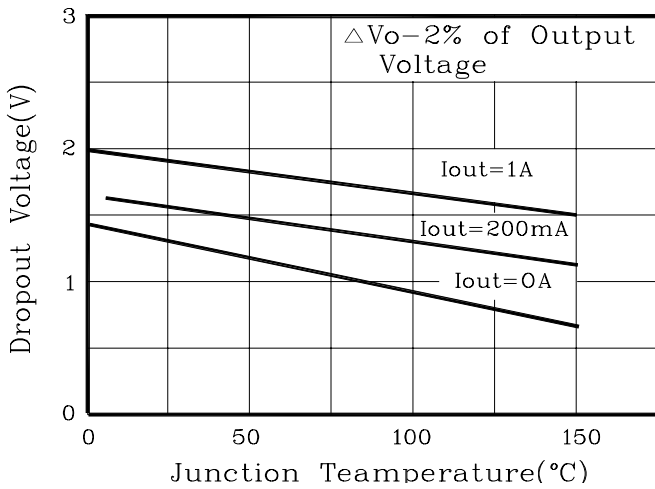

Fig. 2 I_{OUT} vs $|V_{in} - V_{OUT}|$

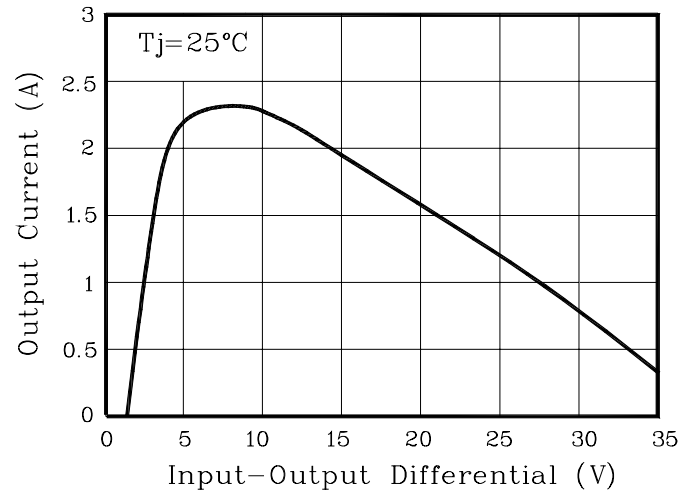

Fig. 3 P_D vs T_a

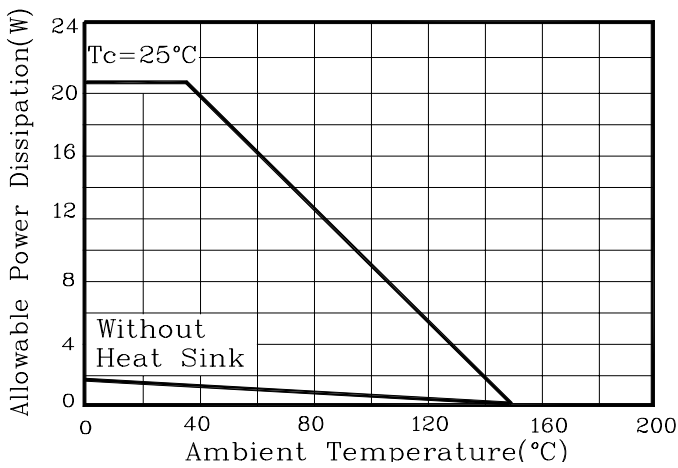

Fig. 4 I_{QC} vs V_{in}

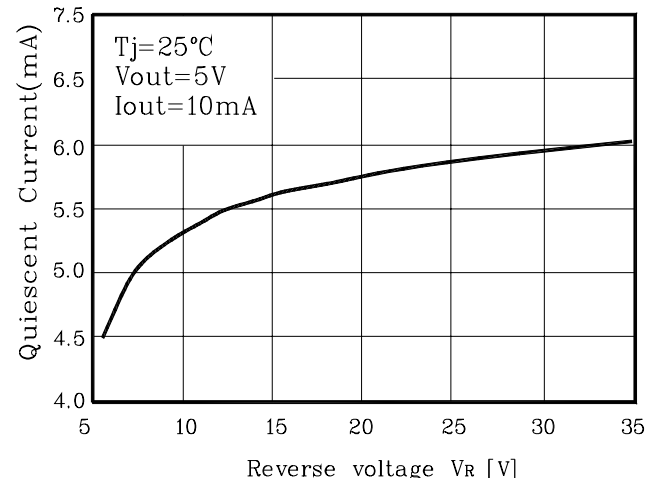

Fig. 5 Ripple Rejection

