

FEATURES

- Integrated Mixer/Oscillator/PLL and IF GCA
- VHF-L, VHF-H, UHF 3-Band Local Oscillator
- RF AGC Detector Circuit
- External 4-Pin IF Filter Between Mixer Output and IF Amplifier Input
- I²C Bus Protocol Bidirectional Data Transmission
- High-Voltage Tuning Voltage Output
- Four NPN-Type Band-Switch Drivers
- One Auxiliary Port/5-Level ADC
- Crystal Oscillator Output
- Programmable Reference Divider Ratio (24/28/50/64/80/128)
- Low Distortion IF Gain Controlled Amplifier
- Standby Mode
- 5-V Power Supply
- 44-Pin Thin Shrink Small-Outline Package (TSSOP)

APPLICATIONS

- Digital TV
- Digital CATV
- Set-Top Box

DESCRIPTION

The SN761668 is a low-phase-noise synthesized tuner IC designed for digital TV tuning systems. The circuit consists of a PLL synthesizer, three-band local oscillator and mixer, RF AGC detector circuit, and IF gain-controlled amplifier. The SN761668 is available in a small-outline package.

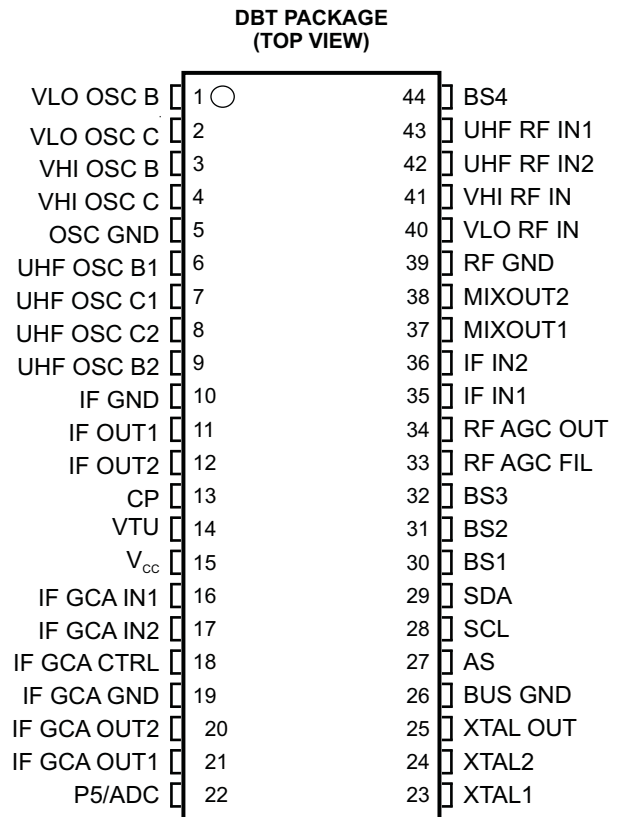

Please be aware that an important notice concerning availability, standard warranty, and use in critical applications of Texas Instruments semiconductor products and disclaimers thereto appears at the end of this data sheet.

FUNCTIONAL BLOCK DIAGRAM

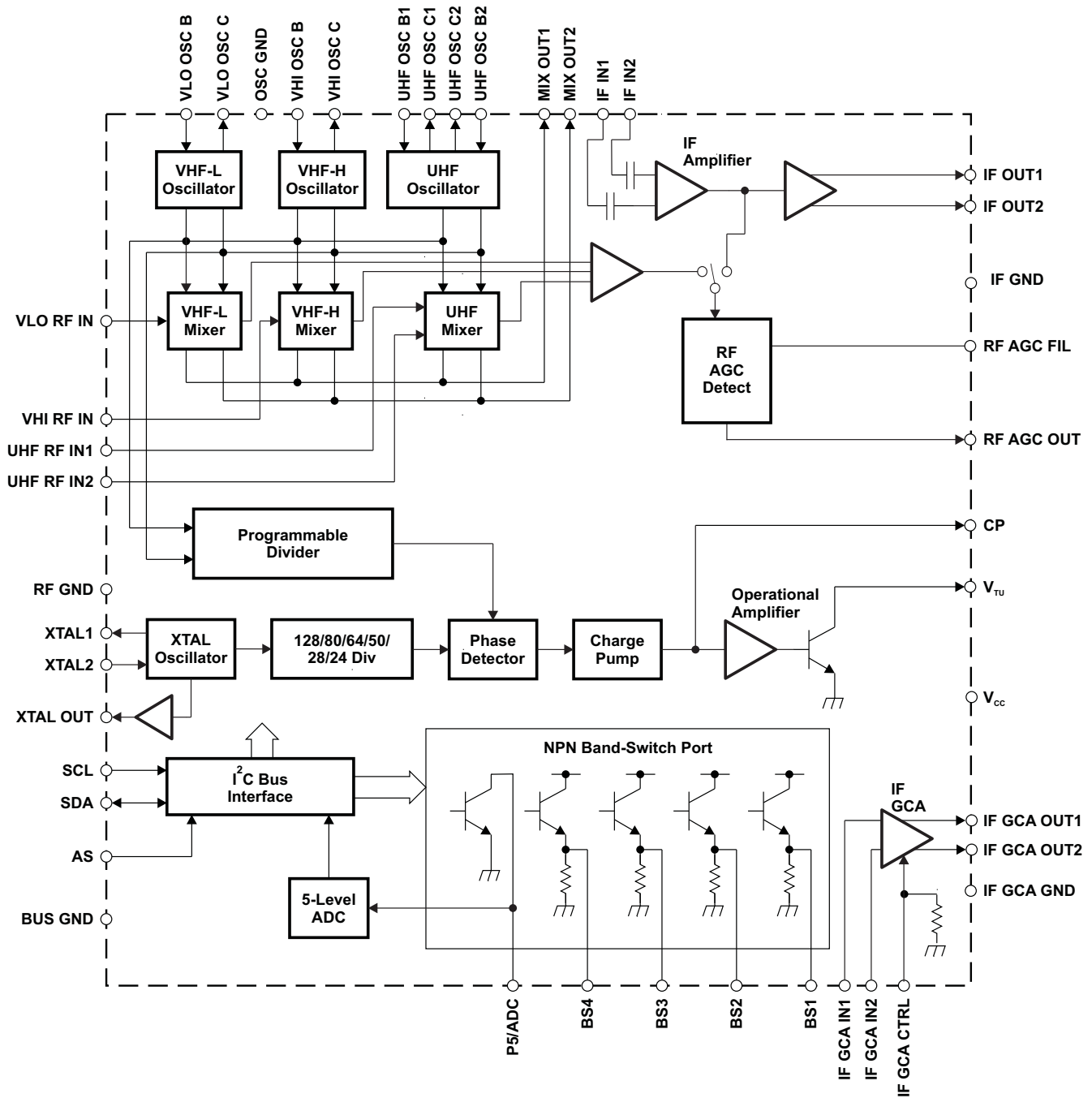

TERMINAL FUNCTIONS

TERMINAL NAME		NO.	DESCRIPTION	SCHEMATIC
AS		27	Address selection input	Figure 1
BS1		30	Band-switch 1 output	Figure 2
BS2		31	Band-switch 2 output	Figure 2
BS3		32	Band-switch 3 output	Figure 2
BS4		44	Band-switch 4 output	Figure 2
BUS GND		26	BUS ground	
CP		13	Charge-pump output	Figure 3
IF GCA CTRL		18	IF GCA CTRL voltage inout	Figure 4
IF GCA GND		19	IF GCA ground	
IF GCA IN1		16	IF GCA input 1	Figure 5
IF GCA IN2		17	IF GCA input 2	Figure 5
IF GCA OUT1		21	IF GCA output 1	Figure 6
IF GCA OUT2		20	IF GCA output 2	Figure 6
IF GND		10	IF ground	
IF IN1		35	IF amplifier input 1	Figure 7
IF IN2		36	IF amplifier input 2	Figure 7
IF OUT1		11	IF amplifier output 1	Figure 8
IF OUT2		12	IF amplifier output 2	Figure 8
MIX OUT1		37	Mixer output 1	Figure 9
MIX OUT2		38	Mixer output 2	Figure 9
OSC GND		5	Oscillator ground	
P5/ADC		22	Port-5 output/ADC input	Figure 10
RF AGC FIL		33	RF AGC additional capacitor pin	Figure 11
RF AGC OUT		34	RF AGC output	Figure 12
RF GND		39	RF ground	
SCL		28	Serial clock input	Figure 13
SDA		29	Serial data input/output	Figure 14
UHF OSC B1		6	UHF oscillator base 1	Figure 15
UHF OSC B2		9	UHF oscillator base 2	Figure 15
UHF OSC C1		7	UHF oscillator collector 1	Figure 15
UHF OSC C2		8	UHF oscillator collector 2	Figure 15
UHF RF IN1		43	UHF RF input 1	Figure 16
UHF RF IN2		42	UHF RF input 2	Figure 16
V _{cc}		15	Supply voltage for mixer/oscillator/PLL: 5 V	
VHI OSC B		3	VHF HIGH oscillator base	Figure 17
VHI OSC C		4	VHF HIGH oscillator collector	Figure 17
VHI RF IN		41	VHF-H RF input	Figure 18
VLO OSC B		1	VHF LOW oscillator base	Figure 19
VLO OSC C		2	VHF LOW oscillator collector	Figure 19
VLO RF IN		40	VHF-L RF input	Figure 20
VTU		14	Tuning voltage amplifier output	Figure 3
XTAL1		23	4-MHz crystal oscillator output	Figure 21
XTAL2		24	4-MHz crystal oscillator input	Figure 21
XTALOUT		25	4-MHz crystal oscillator output	Figure 22

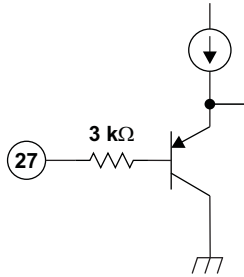

Figure 1. AS

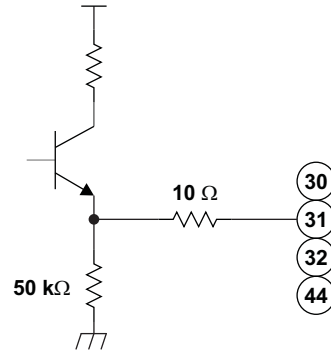

Figure 2. BS1, BS2, BS3, and BS4

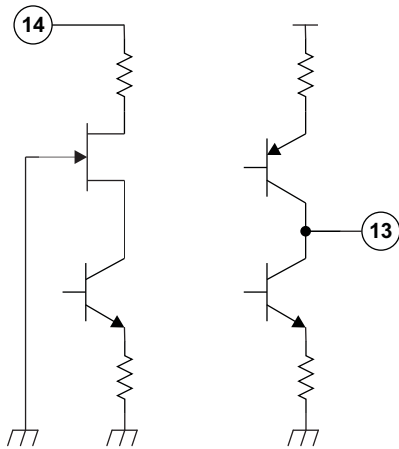

Figure 3. CP and VTU

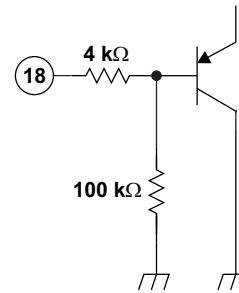

Figure 4. IF GCA CTRL

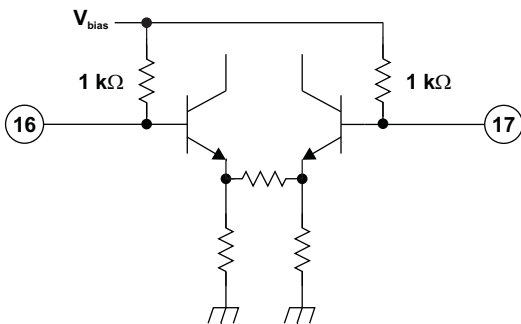

Figure 5. IF GCA IN1 and IF GCA IN2

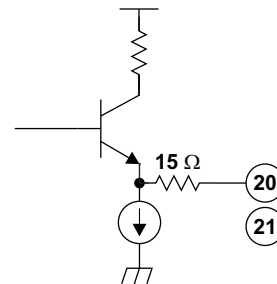

Figure 6. IF GCA OUT1 and IF GCA OUT2

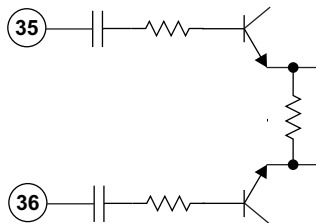

Figure 7. IF IN1 and IF IN2

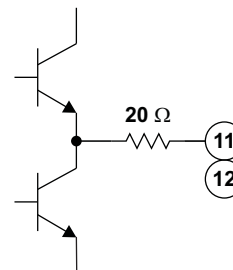

Figure 8. IF OUT1 and IF OUT2

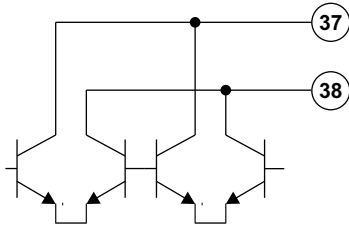

Figure 9. MIX OUT1 and MIX OUT2

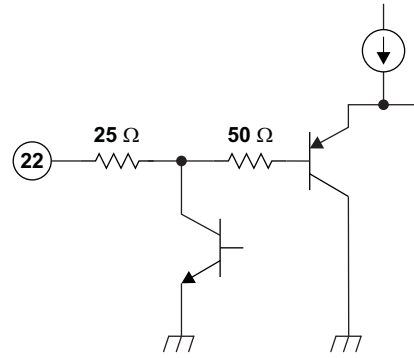

Figure 10. P5/ADC

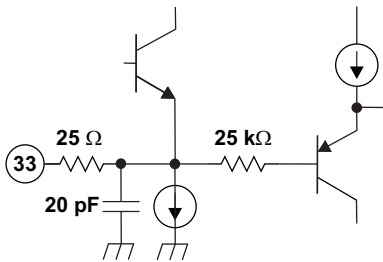

Figure 11. RF AGC FIL

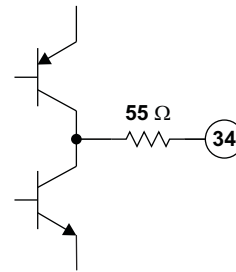

Figure 12. RF AGC OUT

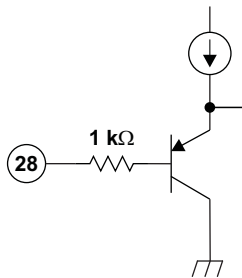

Figure 13. SCL

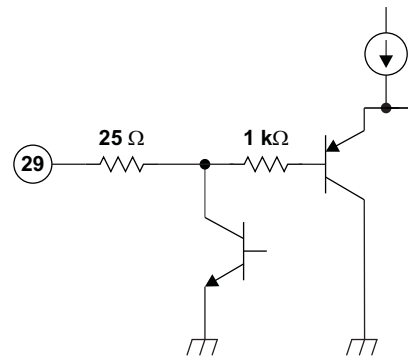

Figure 14. SDA

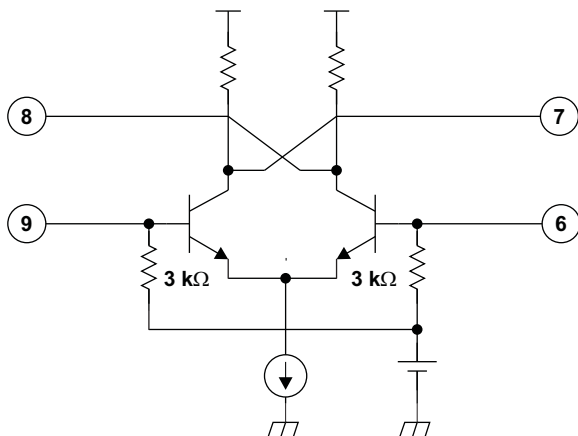

Figure 15. UHF OSC B1, UHF OSC B2, UHF OSC C1, and UHF OSC C2

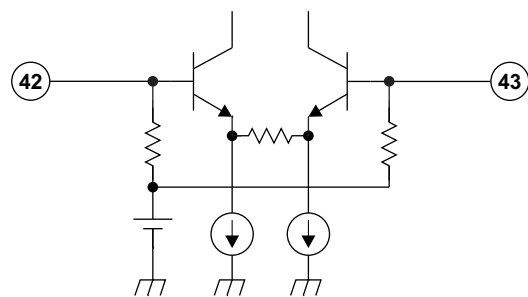

Figure 16. UHF RF IN1 and UHF RF IN2

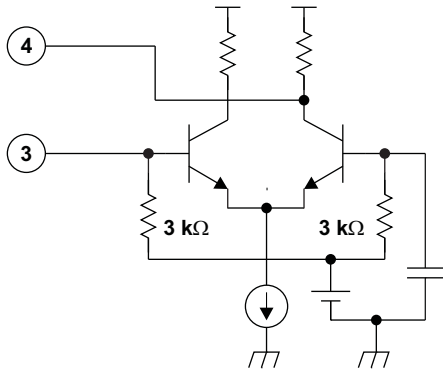

Figure 17. VHI OSC B and VHI OSC C

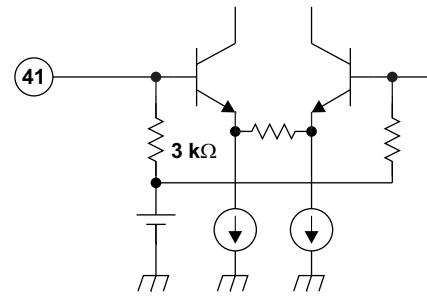

Figure 18. VHI RF IN

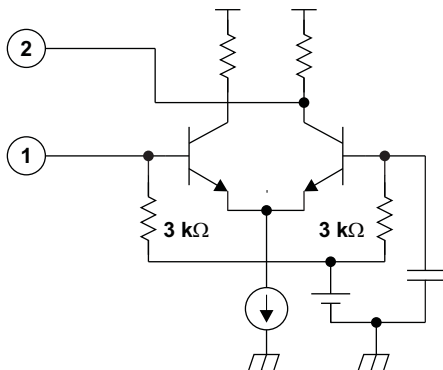

Figure 19. VLO OSC B and VLO OSC C

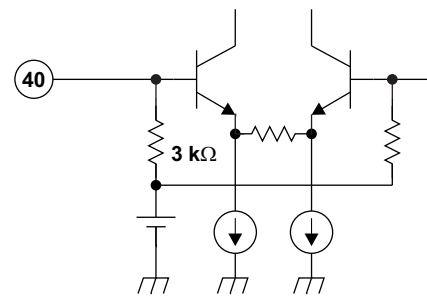

Figure 20. VLO RF IN

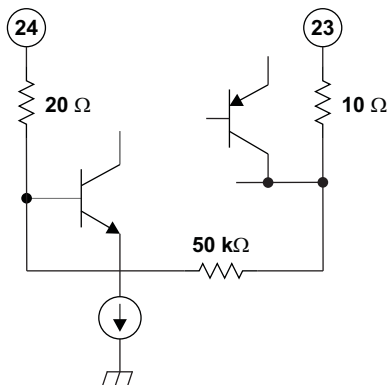

Figure 21. XTAL1 and XTAL2

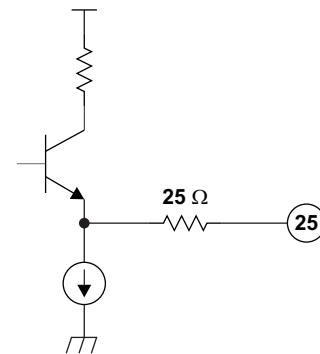

Figure 22. XTAL OUT

Absolute Maximum Ratings⁽¹⁾

over recommended operating free-air temperature range (unless otherwise noted)

			MIN	MAX	UNIT
V _{CC}	Supply voltage range ⁽²⁾	V _{CC}	-0.4	6.5	V
V _{GND}	Input voltage 1 ⁽²⁾	RF GND, OSC GND	-0.4	0.4	V
VTU	Input voltage 2 ⁽²⁾	VTU	-0.4	35	V
V _{IN}	Input voltage 3 ⁽²⁾	Other pins	-0.4	6.5	V
P _D	Continuous total dissipation ⁽³⁾	T _A ≤ 25°C		1438	mW
T _A	Operating free-air temperature range		-20	85	°C
T _{stg}	Storage temperature range		-65	150	°C
T _J	Maximum junction temperature			150	°C
t _{SC(max)}	Maximum short-circuit time	Each pin to V _{CC} or to GND		10	s

- (1) Stresses beyond those listed under "absolute maximum ratings" may cause permanent damage to the device. These are stress ratings only, and functional operation of the device at these or any other conditions beyond those indicated under "recommended operating conditions" is not implied. Exposure to absolute-maximum-rated conditions for extended periods may affect device reliability.
- (2) Voltage values are with respect to the IF GND of the circuit.
- (3) Derating factor is 11.5 mW/°C for T_A ≥ 25°C.

Recommended Operating Conditions

			MIN	NOM	MAX	UNIT
V _{CC}	Supply voltage		4.5	5	5.5	V
VTU	Tuning supply voltage			30	33	V
I _{BS}	Output current of band switch	BS1 – BS4, one band switch on			10	mA
I _{P5}	Output current of port 5	P5/ADC			-5	mA
T _A	Operating free-air temperature		-20		85	°C



This integrated circuit can be damaged by ESD. Texas Instruments recommends that all integrated circuits be handled with appropriate precautions. Failure to observe proper handling and installation procedures can cause damage.

IF IN1, IF IN2, MIXOUT1, and MIXOUT2 (Pins 35 – 38) withstand 1.5 kV, and all other pins withstand 2 kV, according to the Human-Body Model (1.5 kΩ, 100 pF).

Electrical Characteristics – Total Device and Serial Interface

$V_{CC} = 4.5\text{ V to }5.5\text{ V}$, $T_A = -20^\circ\text{C to }85^\circ\text{C}$ (unless otherwise noted)

PARAMETER		TEST CONDITIONS	MIN	TYP	MAX	UNIT
I_{CC1}	Supply current 1			115	140	mA
I_{CC2}	Supply current 2	One band switch on ($I_{BS} = 10\text{ mA}$)		125	150	mA
$I_{CC-STBY}$	Standby supply current	STBY = 1		9		mA
V_{IH}	High-level input voltage (SCL, SDA)		2.5			V
V_{IL}	Low-level input voltage (SCL, SDA)				1.35	V
I_{IH}	High-level input current (SCL, SDA)				10	μA
I_{IL}	Low-level input current (SCL, SDA)		-10			μA
V_{POR}	Power-on-reset supply voltage (threshold of supply voltage between reset and operation mode)		2.1	2.8	3.5	V
I²C Interface						
V_{ASH}	Address-select high-input voltage (AS)	$V_{CC} = 5\text{ V}$	4.5		5	V
V_{ASM1}	Address-select mid-input 1 voltage (AS)	$V_{CC} = 5\text{ V}$	2		3	V
V_{ASM2}	Address-select mid-input 2 voltage (AS)	$V_{CC} = 5\text{ V}$	1		1.5	V
V_{ASL}	Address-select low-input voltage (AS)	$V_{CC} = 5\text{ V}$			0.5	V
I_{ASH}	Address-select high-input current (AS)				10	μA
I_{ASL}	Address-select low-input current (AS)		-10			μA
V_{ADC}	ADC input voltage	See Table 10	0		V_{CC}	V
I_{ADH}	ADC high-level input current	$V_{ADC} = V_{CC}$			10	μA
I_{ADL}	ADC low-level input current	$V_{ADC} = 0\text{ V}$	-10			μA
V_{OL}	Low-level output voltage (SDA)	$V_{CC} = 5\text{ V}$, $I_{OL} = 3\text{ mA}$			0.4	V
I_{SDAH}	High-level output leakage current (SDA)	$V_{SDA} = 5.5\text{ V}$			10	μA
f_{SCL}	Clock frequency (SCL)			100	400	kHz
t_{HD-DAT}	Data hold time	See Figure 23	0			μs
t_{BUF}	Bus free time		1.3			μs
t_{HD-STA}	Start hold time		0.6			μs
t_{LOW}	SCL-low hold time		0.6			μs
t_{HIGH}	SCL-high hold time		0.6			μs
t_{SU-STA}	Start setup time		0.6			μs
t_{SU-DAT}	Data setup time		0.1			μs
t_r	Rise time (SCL, SDA)				0.3	μs
t_f	Fall time (SCL, SDA)				0.3	μs
t_{SU-STO}	Stop setup time		0.6			μs

Electrical Characteristics – PLL and Band Switch

$V_{CC} = 4.5\text{ V to }5.5\text{ V}$, $T_A = -20^\circ\text{C to }85^\circ\text{C}$ (unless otherwise noted)

PARAMETER		TEST CONDITIONS	MIN	TYP	MAX	UNIT
N	Divider ratio	15-bit frequency word	512		32767	
f_{XTAL}	Crystal oscillator frequency	$R_{XTAL} = 25\ \Omega$ to $300\ \Omega$		4		MHz
Z_{XTAL}	Crystal oscillator input impedance			1.6		k Ω
V_{XLO}	XTALOUT output voltage	Load = 10 pF/5.1 k Ω , $V_{CC} = 5\text{ V}$, $T_A = 25^\circ\text{C}$		0.4		V _{p-p}
V_{VTUL}	Tuning amplifier low-level output voltage	$R_L = 20\text{ k}\Omega$, $VTU = 33\text{ V}$	0.2	0.3	0.46	V
I_{VTUOFF}	Tuning amplifier leakage current	Tuning amplifier = off, $VTU = 33\text{ V}$			10	μA
I_{CP11}	Charge-pump current	CP[1:0] = 11		600		μA
I_{CP10}		CP[1:0] = 10		350		
I_{CP01}		CP[1:0] = 01		140		
I_{CP00}		CP[1:0] = 00		70		
V_{CP}	Charge-pump output voltage	PLL locked		1.95		V
I_{CPOFF}	Charge-pump leakage current	$V_{CP} = 2\text{ V}$, $T_A = 25^\circ\text{C}$	-15		15	nA
I_{BS}	Band-switch driver output current (BS1–BS4)				10	mA
V_{BS1}	Band-switch driver output voltage (BS1–BS4)	$I_{BS} = 10\text{ mA}$		3		V
V_{BS2}		$I_{BS} = 10\text{ mA}$, $V_{CC} = 5\text{ V}$, $T_A = 25^\circ\text{C}$		3.5	3.9	
I_{BSOFF}	Band-switch driver leakage current (BS1–BS4)	$V_{BS} = 0\text{ V}$			8	μA
I_{P5}	Band-switch port sink current (P5/ADC)				-5	mA
V_{P5ON}	Band-switch port output voltage (P5/ADC)	$I_{P5} = -2\text{ mA}$, $V_{CC} = 5\text{ V}$, $T_A = 25^\circ\text{C}$			0.6	V

Electrical Characteristics – RF AGC

$V_{CC} = 5\text{ V}$, $T_A = 25^\circ\text{C}$, measured in [Figure 24](#) reference measurement circuit at 50- Ω system, IF = 44 MHz, IF filter characteristics: $f_{peak} = 44\text{ MHz}$ (unless otherwise noted)

PARAMETER		TEST CONDITIONS	TYP	UNIT
I_{OAGC0}	RF AGC output current	ATC = 0	300	nA
I_{OAGC1}		ATC = 1	15	μA
$I_{OAGCSINK}$	RF AGC peak sink current	ATC = 0	100	μA
$V_{AGCSP00}$	Start-point IF output level ⁽¹⁾	T1/ATSS = 0, ATP[2:0] = 000	117	dB μV
$V_{AGCSP01}$		T1/ATSS = 0, ATP[2:0] = 001	114	
$V_{AGCSP02}$		T1/ATSS = 0, ATP[2:0] = 010	111	
$V_{AGCSP03}$		T1/ATSS = 0, ATP[2:0] = 011	108	
$V_{AGCSP04}$		T1/ATSS = 0, ATP[2:0] = 100	105	
$V_{AGCSP05}$		T1/ATSS = 0, ATP[2:0] = 101	102	
$V_{AGCSP06}$		T1/ATSS = 0, ATP[2:0] = 110	99	
$V_{AGCSP10}$		T1/ATSS = 1, ATP[2:0] = 000	112	
$V_{AGCSP11}$		T1/ATSS = 1, ATP[2:0] = 001	109	
$V_{AGCSP12}$		T1/ATSS = 1, ATP[2:0] = 010	106	
$V_{AGCSP13}$		T1/ATSS = 1, ATP[2:0] = 011	103	
$V_{AGCSP14}$		T1/ATSS = 1, ATP[2:0] = 100	100	
$V_{AGCSP15}$		T1/ATSS = 1, ATP[2:0] = 101	97	
$V_{AGCSP16}$		T1/ATSS = 1, ATP[2:0] = 110	94	

(1) When AISL = 1, RF AGC function is not available at VHF-L band.

Electrical Characteristics – Mixer, Oscillator, IF Amplifier

$V_{CC} = 5\text{ V}$, $T_A = 25^\circ\text{C}$, measured in [Figure 24](#) reference measurement circuit at 50- Ω system, IF = 44 MHz, IF filter characteristics: $f_{peak} = 44\text{ MHz}$ (unless otherwise noted)

PARAMETER		TEST CONDITIONS	TYP	UNIT
G_{c1}	Conversion gain (mixer-IF amplifier), VHF-LOW	$f_{in} = 57\text{ MHz}^{(1)}$	35	dB
G_{c3}		$f_{in} = 171\text{ MHz}^{(1)}$	35	
G_{c4}	Conversion gain (mixer-IF amplifier), VHF-HIGH	$f_{in} = 177\text{ MHz}^{(1)}$	35	dB
G_{c6}		$f_{in} = 467\text{ MHz}^{(1)}$	35	
G_{c7}	Conversion gain (mixer-IF amplifier), UHF	$f_{in} = 473\text{ MHz}^{(1)}$	35	dB
G_{c9}		$f_{in} = 864\text{ MHz}^{(1)}$	35	
NF_1	Noise figure, VHF-LOW	$f_{in} = 57\text{ MHz}$	9	dB
NF_3		$f_{in} = 171\text{ MHz}$	9	
NF_4	Noise figure, VHF-HIGH	$f_{in} = 177\text{ MHz}$	9	dB
NF_6		$f_{in} = 467\text{ MHz}$	9	
NF_7	Noise figure, UHF	$f_{in} = 473\text{ MHz}$	12	dB
NF_9		$f_{in} = 864\text{ MHz}$	12	
CM_1	Input voltage causing 1% cross-modulation distortion, VHF-LOW	$f_{in} = 57\text{ MHz}^{(2)}$	79	dB μ V
CM_3		$f_{in} = 171\text{ MHz}^{(2)}$	79	
CM_4	Input voltage causing 1% cross-modulation distortion, VHF-HIGH	$f_{in} = 177\text{ MHz}^{(2)}$	79	dB μ V
CM_6		$f_{in} = 467\text{ MHz}^{(2)}$	79	
CM_7	Input voltage causing 1% cross-modulation distortion, UHF	$f_{in} = 473\text{ MHz}^{(2)}$	77	dB μ V
CM_9		$f_{in} = 864\text{ MHz}^{(2)}$	77	
V_{IF01}	IF output voltage, VHF-LOW	$f_{in} = 57\text{ MHz}$	117	dB μ V
V_{IF03}		$f_{in} = 171\text{ MHz}$	117	
V_{IF04}	IF output voltage, VHF-HIGH	$f_{in} = 177\text{ MHz}$	117	dB μ V
V_{IF06}		$f_{in} = 467\text{ MHz}$	117	
V_{IF07}	IF output voltage, UHF	$f_{in} = 473\text{ MHz}$	117	dB μ V
V_{IF09}		$f_{in} = 864\text{ MHz}$	117	
Φ_{PLVL11}	Phase noise, VHF-LOW	$f_{in} = 57\text{ MHz}$, Offset = 1 kHz ⁽³⁾	-90	dBc/Hz
Φ_{PLVL12}		$f_{in} = 57\text{ MHz}$, Offset = 10 kHz ⁽⁴⁾	-95	
Φ_{PLVL31}		$f_{in} = 171\text{ MHz}$, Offset = 1 kHz ⁽⁵⁾	-85	
Φ_{PLVL32}		$f_{in} = 171\text{ MHz}$, Offset = 10 kHz ⁽⁴⁾	-95	
Φ_{PLVL41}	Phase noise, VHF-HIGH	$f_{in} = 177\text{ MHz}$, Offset = 1 kHz ⁽³⁾	-85	dBc/Hz
Φ_{PLVL42}		$f_{in} = 177\text{ MHz}$, Offset = 10 kHz ⁽⁴⁾	-90	
Φ_{PLVL61}		$f_{in} = 467\text{ MHz}$, Offset = 1 kHz ⁽⁵⁾	-77	
Φ_{PLVL62}		$f_{in} = 467\text{ MHz}$, Offset = 10 kHz ⁽⁴⁾	-90	
Φ_{PLVL71}	Phase noise, UHF	$f_{in} = 473\text{ MHz}$, Offset = 1 kHz ⁽³⁾	-80	dBc/Hz
Φ_{PLVL72}		$f_{in} = 473\text{ MHz}$, Offset = 10 kHz ⁽⁴⁾	-85	
Φ_{PLVL91}		$f_{in} = 864\text{ MHz}$, Offset = 1 kHz ⁽⁵⁾	-77	
Φ_{PLVL92}		$f_{in} = 864\text{ MHz}$, Offset = 10 kHz ⁽⁴⁾	-90	

- (1) IF = 44 MHz, RF input level = 70 dB μ V, differential output
- (2) $f_{undes} = f_{des} \pm 6\text{ MHz}$, $P_{in} = 70\text{ dB}\mu\text{V}$, AM 1 kHz, 30%, DES/CM = S/I = 46 dB
- (3) CP[1:0] = 10 (CP current 350 μ A), RS[2:0] = 011 (reference divider 64)
- (4) CP[1:0] = 00 (CP current 70 μ A), RS[2:0] = 100 (reference divider 128)
- (5) CP[1:0] = 11 (CP current 600 μ A), RS[2:0] = 011 (reference divider 64)

Electrical Characteristics – IF Gain Controlled Amplifier

$V_{CC} = 5\text{ V}$, $T_A = 25^\circ\text{C}$, measured in Figure 24 reference measurement circuit at 50- Ω system, $f_{IF} = 44\text{ MHz}$, (unless otherwise noted)

PARAMETER		TEST CONDITIONS	MIN	TYP	MAX	UNIT
I_{IFGCA}	Input current (IF GCA CTRL)	$V_{IFGCA} = 3\text{ V}$		30	60	μA
$V_{IFGCAMAX}$	Maximum gain control voltage	Gain maximum	2.5		V_{CC}	V
$V_{IFGCAMIN}$	Minimum gain control voltage	Gain minimum	0		0.4	V
$G_{IFGCAMAX}$	Maximum gain	$V_{IFGCA} = 3\text{ V}$	49	53	57	dB
$G_{IFGCAMIN}$	Minimum gain	$V_{IFGCA} = 0\text{ V}$	-4	-1	2	dB
GCR_{IFGCA}	Gain control range	$V_{IFGCA} = 0\text{--}3\text{ V}$		54		dB
$V_{IFGCAOUT}$	Output voltage	Single-ended output		2.1		Vp-pF
NF_{IFGCA}	Noise figure	$V_{IFGCA} = 3\text{ V}$		8.5		dB
$IM3_{IFGCA}$	Third order intermodulation distortion	$f_{IFGCAIN1} = 43\text{ MHz}$, $f_{IFGCAIN2} = 44\text{ MHz}$, $V_{IFGCAOUT} = -2\text{ dBm}$, $V_{IFGCA} = 3\text{ V}$		-50		dBc
$IIP3_{IFGCA}$	Input intercept point	$V_{IFGCA} = 0\text{ V}$		11		dBm
$R_{IFGCAIN}$	Input resistance (IF GCA IN1, IF GCA IN2)			1		k Ω

Functional Description

I²C Bus Mode

I²C Write Mode ($R/\overline{W} = 0$)

Table 1. Write Data Format

	MSB							LSB	(1)
Address byte (ADB)	1	1	0	0	0	MA1	MA0	$R/\overline{W} = 0$	A
Divider byte 1 (DB1)	0	N14	N13	N12	N11	N10	N9	N8	A
Divider byte 2 (DB2)	N7	N6	N5	N4	N3	N2	N1	N0	A
Control byte 1 (CB1)	1	0	ATP2	ATP1	ATP0	RS2	RS1	RS0	A
Band-switch byte (BB)	CP1	CP0	AISL	P5	BS4	BS3	BS2	BS1	A
Control byte 2 (CB2)	1	1	ATC	STBY	T3	T2	T1/ATSS	T0/XLO	A

(1) A: Acknowledge

Table 2. Write Data Symbol Description

SYMBOL	DESCRIPTION	DEFAULT
MA[1:0]	Address-set bits (see Table 3)	
N[14:0]	Programmable counter set bits $N = N14 \times 2^{14} + N13 \times 2^{13} + \dots + N1 \times 2 + N0$	$N14 = N13 = N12 = \dots = N0 = 0$
ATP[2:0]	RF AGC start-point control bits (see Table 4)	ATP[2:0] = 011
RS[2:0]	Reference divider ratio-selection bits (see Table 5)	RS[2:0] = 111
CP[1:0]	Charge-pump current-set bit (see Table 6)	CP[1:0] = 11
AISL	RF AGC detector input selection bit AISL = 0: IF amplifier AISL = 1: Mixer output	AISL = 0
P5	Port output/ADC input control bit P5 = 0: ADC INPUT P5 = 1: Tr = ON	P5 = 0

Table 2. Write Data Symbol Description (continued)

SYMBOL	DESCRIPTION	DEFAULT													
BS[4:1]	Band-switch control bits BSn = 0: Tr = OFF BSn = 1: Tr = ON	BSn = 0													
	Band selection by BS[1:2] <table border="1"> <thead> <tr> <th>BS1</th> <th>BS2</th> <th></th> </tr> </thead> <tbody> <tr> <td>1</td> <td>0</td> <td>VHF-LO</td> </tr> <tr> <td>0</td> <td>1</td> <td>VHF-HI</td> </tr> <tr> <td>0</td> <td>0</td> <td>UHF</td> </tr> <tr> <td>1</td> <td>1</td> <td>Reserved</td> </tr> </tbody> </table>		BS1	BS2		1	0	VHF-LO	0	1	VHF-HI	0	0	UHF	1
BS1	BS2														
1	0	VHF-LO													
0	1	VHF-HI													
0	0	UHF													
1	1	Reserved													
ATC	RF AGC current-set bit ATC = 0: Current = 300 nA ATC = 1: Current = 15 μ A	ATC = 0													
STBY	Power standby mode-control bit STBY = 0: Normal operation STBY = 1: Standby mode/stop MOP function (XTALOUT is available even in standby mode)	STBY = 0													
T3, T2, T1/ATSS, T0/XLO	TEST bits, RFAGC shift bit, XTALOUT control bit (see Table 7)	T[3:0] = 0010													
X	Don't care														

Table 3. Address Selection

MA1	MA0	VOLTAGE APPLIED ON AS INPUT
0	0	0 V to 0.1 V _{CC} (Low)
0	1	OPEN, or 0.2 V _{CC} to 0.3 V _{CC} (Mid2)
1	0	0.4 V _{CC} to 0.6 V _{CC} (Mid1)
1	1	0.9 V _{CC} to V _{CC} (High)

Table 4. RF AGC Start Point⁽¹⁾

T1/ATSS	ATP2	ATP1	ATP0	IFOUT LEVEL (dB _μ V)
0	0	0	0	117
0	0	0	1	114
0	0	1	0	111
0	0	1	1	108
0	1	0	0	105
0	1	0	1	102
0	1	1	0	99
0	1	1	1	Disabled
1	0	0	0	112
1	0	0	1	109
1	0	1	0	106
1	0	1	1	103
1	1	0	0	100
1	1	0	1	97
1	1	1	0	94
1	1	1	1	Disabled

(1) When AISL = 1, RF AGC function is not available at VHF-L band (output level is undefined).

Table 5. Reference Divider Ratio

RS2	RS1	RS0	REFERENCE DIVIDER RATIO
0	0	0	24
0	0	1	28
0	1	0	50
0	1	1	64
1	0	0	128
1	X	1	80

Table 6. Charge-Pump Current

CP1	CP0	CHARGE PUMP CURRENT (μA)
0	0	70
0	1	140
1	0	350
1	1	600

Table 7. Test Bits/XTALOUT Control ⁽¹⁾

T3	T2	T1/ATSS	T0/XLO	DEVICE OPERATION	XTALOUT 4-MHz OUTPUT
0	0	X	0	Normal operation	Enabled
0	0	X	1	Normal operation	Disabled
X	1	X	X	Test mode	Not available
1	X	X	X	Test mode	Not available

(1) RFAGC and XTALOUT are not available in test mode.

Example I²C Data Write Sequences

Telegram examples:

Start-ADB-DB1-DB2-CB1-BB-CB2-Stop
Start-ADB-DB1-DB2-Stop
Start-ADB-CB1-BB-CB2-Stop
Start-ADB-CB1-BB-Stop
Start-ADB-CB2-Stop

Abbreviations:

ADB: Address byte
BB: Band-switch byte
CB1: Control byte 1
CB2: Control byte 2
DB1: Divider byte 1
DB2: Divider byte 2
Start: Start condition
Stop: Stop condition

I²C Read Mode ($R/\overline{W} = 1$)

Table 8. Read Data Format (A: Acknowledge)

	MSB							LSB		
Address byte (ADB)	1	1	0	0	0	0	MA1	MA0	$R/\overline{W} = 1$	A
Status byte (SB)	POR	FL	1	1	X		A2	A1	A0	–

Table 9. Read Data Symbol Description

SYMBOL	DESCRIPTION	DEFAULT
MA[1:0]	Address set bits (see Table 3)	
POR	Power-on-reset flag POR set: power on POR reset: end-of-data transmission procedure	POR = 1
FL	In-lock flag PLL locked (FL = 1), unlocked (FL = 0)	
A[2:0]	Digital data of ADC (see Table 10) Bit P5 must be set to 0.	

Table 10. ADC Level⁽¹⁾

A2	A1	A0	VOLTAGE APPLIED ON ADC INPUT
1	0	0	0.6 V _{CC} to V _{CC}
0	1	1	0.45 V _{CC} to 0.6 V _{CC}
0	1	0	0.3 V _{CC} to 0.45 V _{CC}
0	0	1	0.15 V _{CC} to 0.3 V _{CC}
0	0	0	0 V to 0.15 V _{CC}

(1) Accuracy is $0.03 \times V_{CC}$.

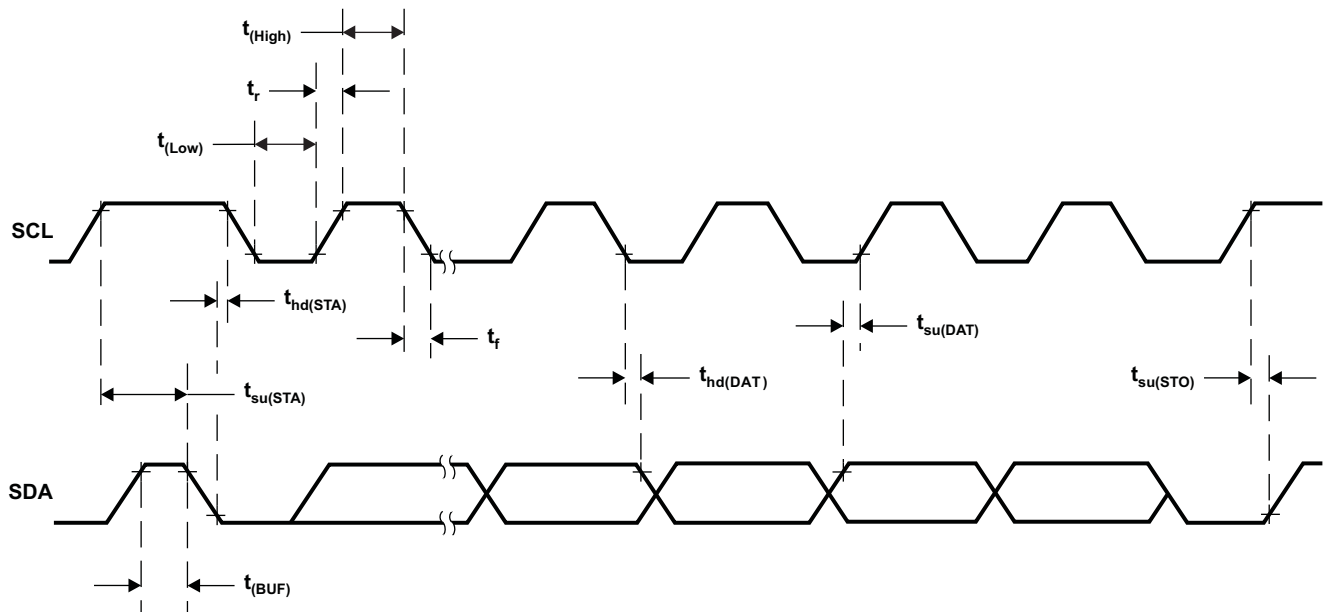
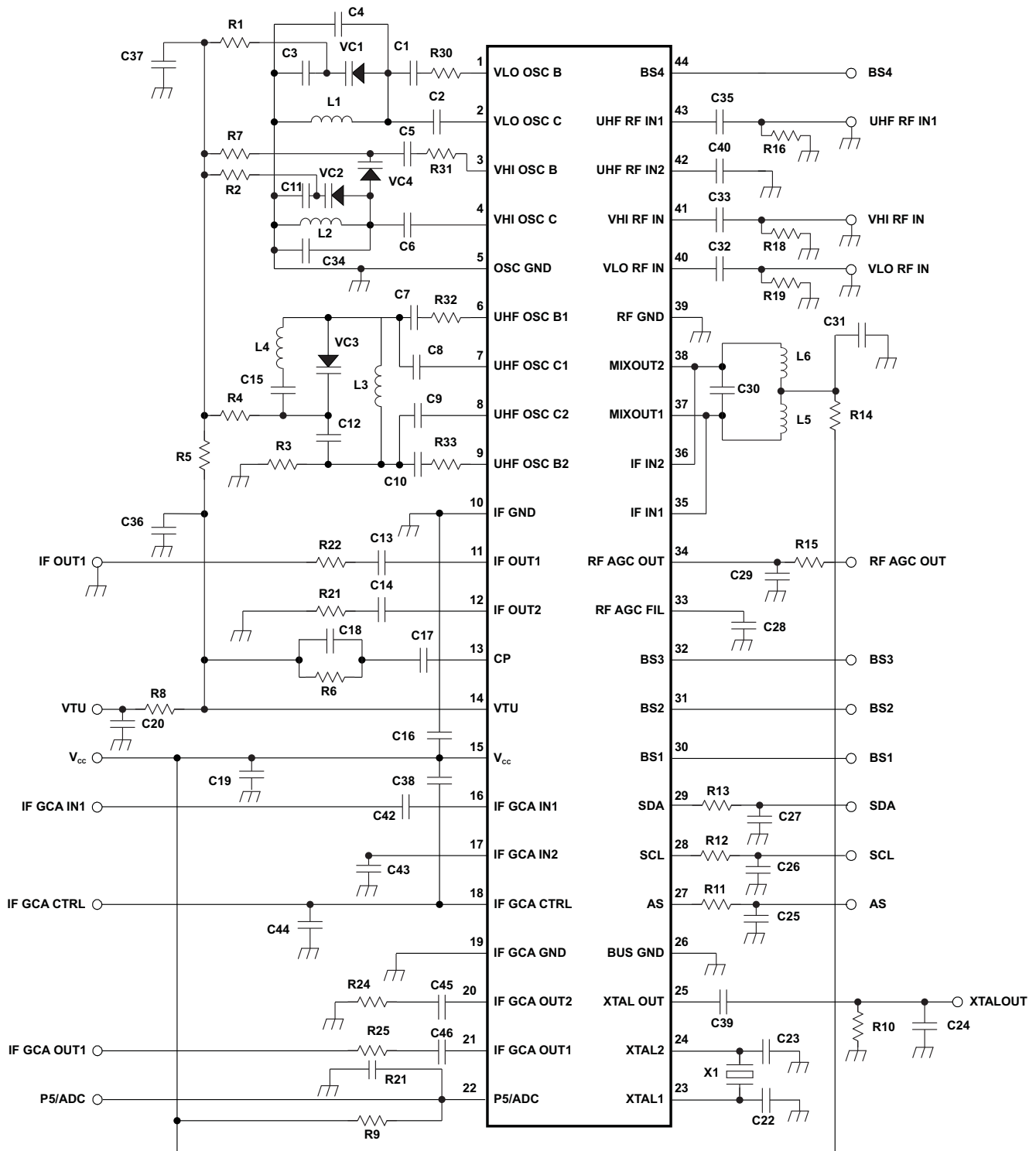

Figure 23. I²C Timing Chart

APPLICATION INFORMATION



NOTE: This application information is advisory, and a performance-check is required for actual application circuits. TI assumes no responsibility for the consequences of the use of this circuit, nor for any infringement of patent or patent rights of third parties that may result from its use.

Figure 24. Reference Measurement Circuit

APPLICATION INFORMATION (continued)
Component Values for Measurement Circuit

PART NAME	VALUE	PART NAME	VALUE
C1 (VLO OSC B)	1 pF	C44 (IF GCA CTRL)	2.2 nF
C2 (VLO OSC C)	2 pF	C45 (IF GCA OUT1)	2.2 nF
C3 (VLO OSC)	47 pF	C46 (IF GCA OUT2)	2.2 nF
C4 (VLO OSC)	Open	L1 (VLO OSC)	φ 3,0 mm, 7T, wire 0,32 mm
C6 (VHI OSC C)	5 pF	L2 (VHI OSC)	φ2,0 mm, 3T, wire 0,4 mm
C7 (UHF OSC B1)	1.5 pF	L3 (UHF OSC)	φ1,8 mm, 3T, wire 0,4 mm
C8 (UHF OSC C1)	1 pF	L4 (UHF OSC)	φ1,8 mm, 3T, wire 0,4 mm
C9 (UHF OSC C2)	1 pF	L5 (MIX OUT)	680 nH (LK1608R68K-T)
C10 (UHF OSC B2)	1.5 pF	L6 (MIX OUT)	680 nH (LK1608R68K-T)
C11 (VHI OSC)	51 pF	R1 (VLO OSC)	3.3 kΩ
C12 (UHF OSC)	10 pF	R2 (VHI OSC)	3.3 kΩ
C13 (IF OUT)	2.2 nF	R3 (UHF OSC)	2.2 kΩ
C14 (IF OUT)	2.2 nF	R4 (UHF OSC)	1 kΩ
C15 (UHF OSC)	100 pF	R5 (VTU)	3 kΩ
C16 (V _{CC})	4.7 nF	R6 (CP)	47 kΩ
C17 (CP)	0.01 μF/50 V	R7 (VHI OSC)	3.3 kΩ
C18 (CP)	22 pF/50 V	R8 (VTU)	20 kΩ
C19 (V _{CC})	2.2 nF	R9 (P5/ADC)	Open
C20 (VTU)	2.2 nF/50 V	R10 (XTALOUT)	5.1 kΩ
C21 (P5/ADC)	Open	R11 (AS)	330 Ω
C22 (XTAL)	27 pF	R12 (SCL)	330 Ω
C23 (XTAL)	27 pF	R13 (SDA)	330 Ω
C24 (XTALOUT)	10 pF	R14 (V _{CC})	0
C25 (AS)	Open	R15 (RF AGC OUT)	0
C26 (SCL)	Open	R16 (UHF RF IN1)	(50 Ω)
C27 (SDA)	Open	R18 (VHI RF IN)	(50 Ω)
C28 (AGC FIL)	Open	R19 (VLO RF IN)	(50 Ω)
C29 (RF AGC OUT)	0.15 μF	R21 (IF OUT2)	1 kΩ
C30 (MIX OUT)	4 pF	R22 (IF OUT1)	1 kΩ
C31 (MIX OUT)	2.2 nF	R24 (IF GCA OUT1)	250 Ω
C32 (VLO RF IN)	2.2 nF	R25 (IF GCA OUT2)	200 Ω
C33 (VHI RF IN)	2.2 nF	R30 (VLO OSC B)	0
C34 (VHI OSC)	0.5 pF	R31 (VHI OSC B)	4.7 Ω
C35 (UHF RF IN1)	2.2 nF	R32 (UHF OSC B1)	0
C36 (VTU)	22 pF	R33 (UHF OSC B2)	0
C37 (VTU)	2.2 nF/50 V	VC1 (VLO OSC)	MA2S374
C38 (V _{CC})	0.1 μF	VC2 (VHI OSC)	MA2S374
C39 (XTAL OUT)	2.2 nF	VC3 (UHF OSC)	MA2S372
C40 (UHF RF IN2)	2.2 nF	VC4 (VHI OSC)	MA2S372
C42 (IF GCA IN1)	2.2 nF	X1	4-MHz crystal
C43 (IF GCA IN1)	2.2 nF		

APPLICATION INFORMATION (CONTINUED)

Test Circuits

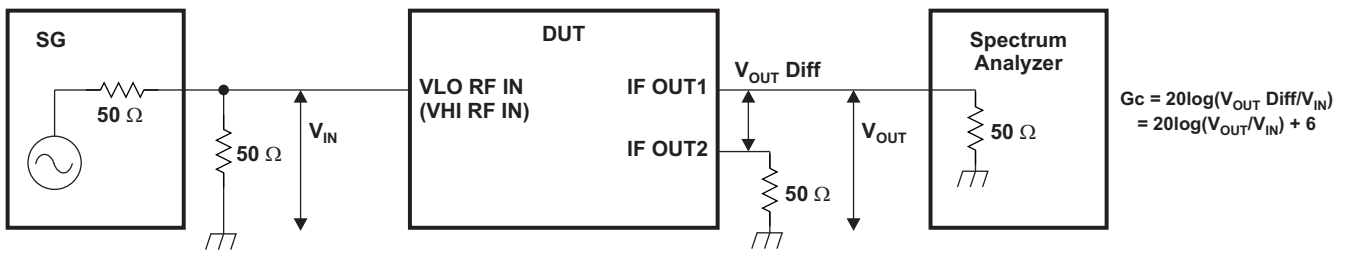

Figure 25. VHF-Conversion Gain-Measurement Circuit

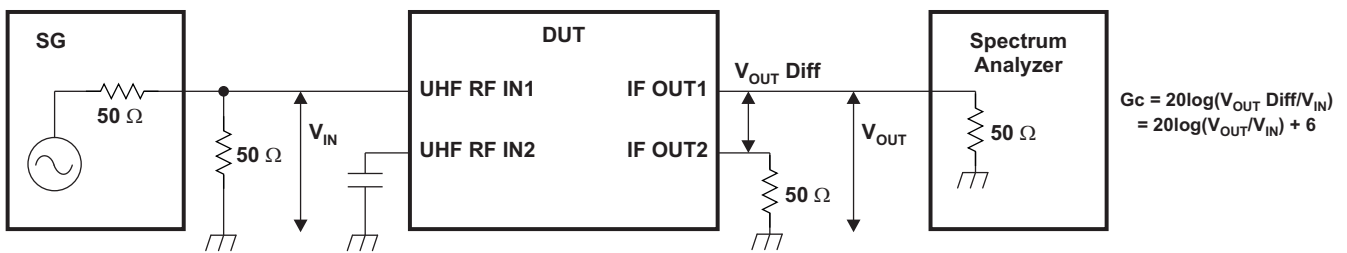

Figure 26. UHF-Conversion Gain-Measurement Circuit

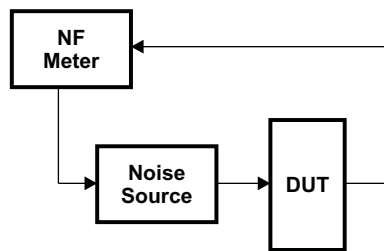

Figure 27. Noise-Figure Measurement Circuit

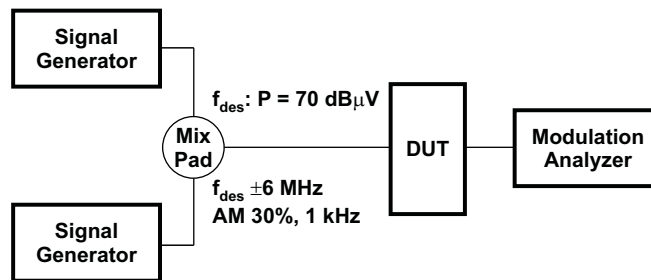

Figure 28. 1% Cross-Modulation Distortion Measurement Circuit

TYPICAL CHARACTERISTICS

Band-Switch Driver Output Voltage (BS1–BS4)

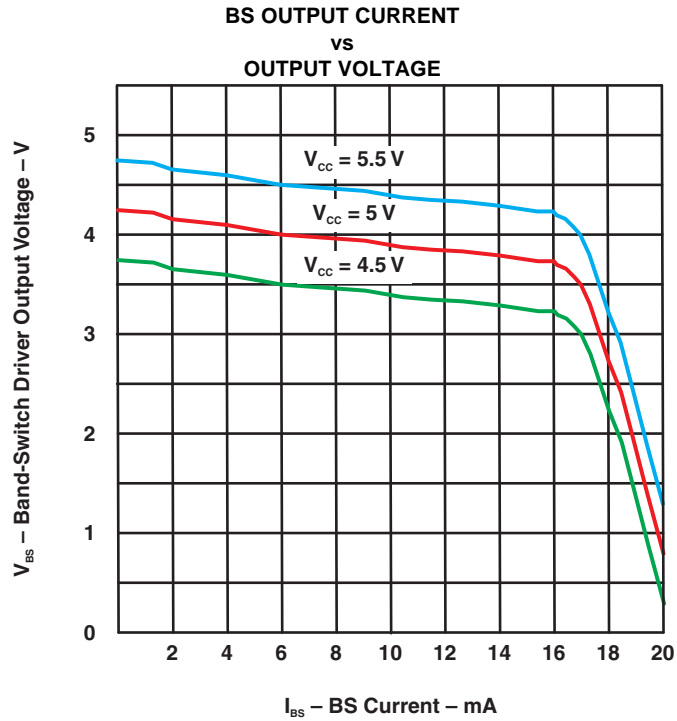

Figure 29. Band-Switch Driver Output Voltage

S-Parameter

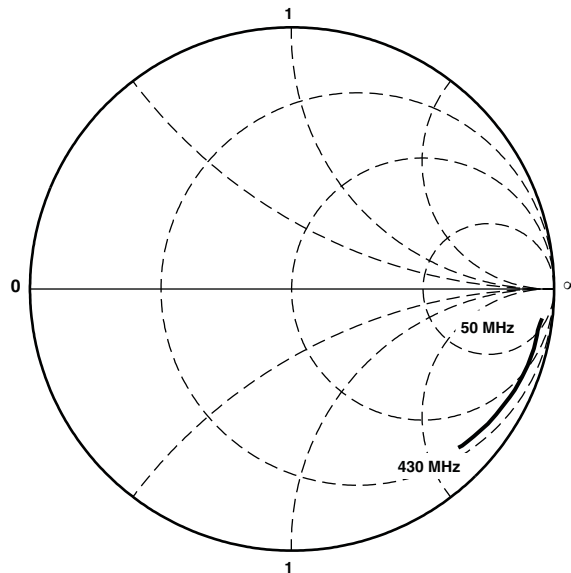

Figure 30. VLO RFIN, VHI RFIN

TYPICAL CHARACTERISTICS (continued)

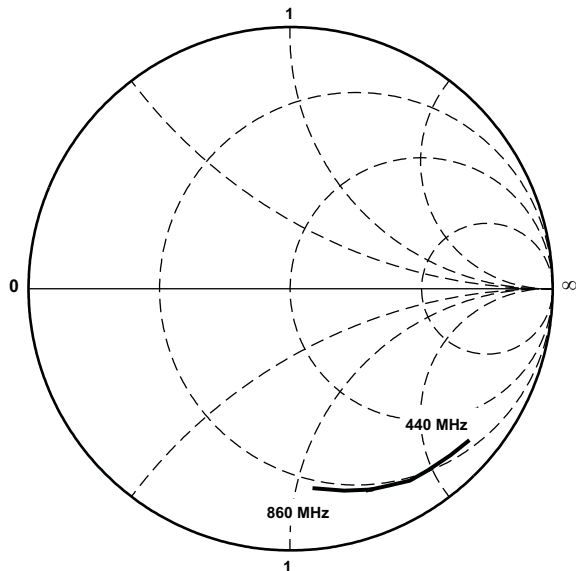

Figure 31. UHF RFIN

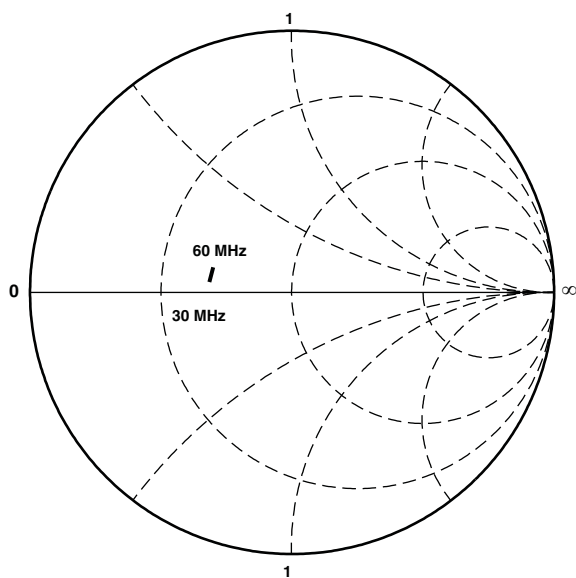

Figure 32. IFOUT

TYPICAL CHARACTERISTICS (continued)

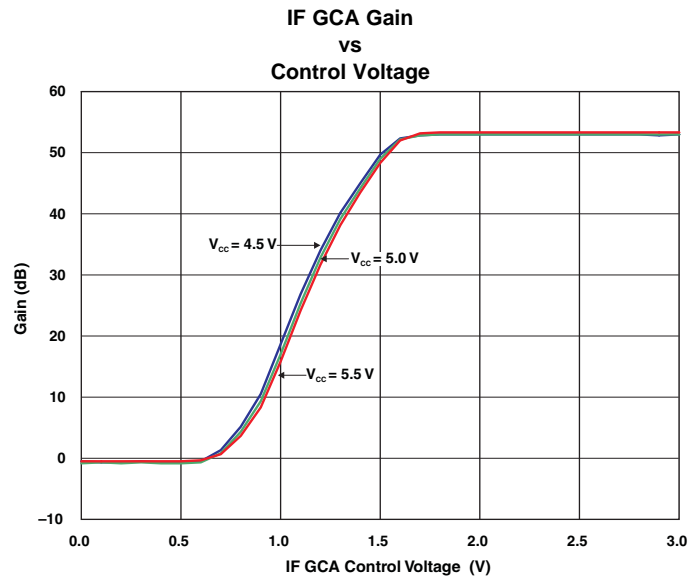

Figure 33. IF GCA Gain vs Control Voltage

PACKAGING INFORMATION

Orderable Device	Status ⁽¹⁾	Package Type	Package Drawing	Pins	Package Qty	Eco Plan ⁽²⁾	Lead/Ball Finish	MSL Peak Temp ⁽³⁾
SN761668DBTR	PREVIEW	SM8	DBT	44	2000	TBD	Call TI	Call TI

⁽¹⁾ The marketing status values are defined as follows:

ACTIVE: Product device recommended for new designs.

LIFEBUY: TI has announced that the device will be discontinued, and a lifetime-buy period is in effect.

NRND: Not recommended for new designs. Device is in production to support existing customers, but TI does not recommend using this part in a new design.

PREVIEW: Device has been announced but is not in production. Samples may or may not be available.

OBSOLETE: TI has discontinued the production of the device.

⁽²⁾ Eco Plan - The planned eco-friendly classification: Pb-Free (RoHS), Pb-Free (RoHS Exempt), or Green (RoHS & no Sb/Br) - please check <http://www.ti.com/productcontent> for the latest availability information and additional product content details.

TBD: The Pb-Free/Green conversion plan has not been defined.

Pb-Free (RoHS): TI's terms "Lead-Free" or "Pb-Free" mean semiconductor products that are compatible with the current RoHS requirements for all 6 substances, including the requirement that lead not exceed 0.1% by weight in homogeneous materials. Where designed to be soldered at high temperatures, TI Pb-Free products are suitable for use in specified lead-free processes.

Pb-Free (RoHS Exempt): This component has a RoHS exemption for either 1) lead-based flip-chip solder bumps used between the die and package, or 2) lead-based die adhesive used between the die and leadframe. The component is otherwise considered Pb-Free (RoHS compatible) as defined above.

Green (RoHS & no Sb/Br): TI defines "Green" to mean Pb-Free (RoHS compatible), and free of Bromine (Br) and Antimony (Sb) based flame retardants (Br or Sb do not exceed 0.1% by weight in homogeneous material)

⁽³⁾ MSL, Peak Temp. -- The Moisture Sensitivity Level rating according to the JEDEC industry standard classifications, and peak solder temperature.

Important Information and Disclaimer:The information provided on this page represents TI's knowledge and belief as of the date that it is provided. TI bases its knowledge and belief on information provided by third parties, and makes no representation or warranty as to the accuracy of such information. Efforts are underway to better integrate information from third parties. TI has taken and continues to take reasonable steps to provide representative and accurate information but may not have conducted destructive testing or chemical analysis on incoming materials and chemicals. TI and TI suppliers consider certain information to be proprietary, and thus CAS numbers and other limited information may not be available for release.

In no event shall TI's liability arising out of such information exceed the total purchase price of the TI part(s) at issue in this document sold by TI to Customer on an annual basis.

DBT (R-PDSO-G**)

30 PINS SHOWN

PLASTIC SMALL-OUTLINE PACKAGE

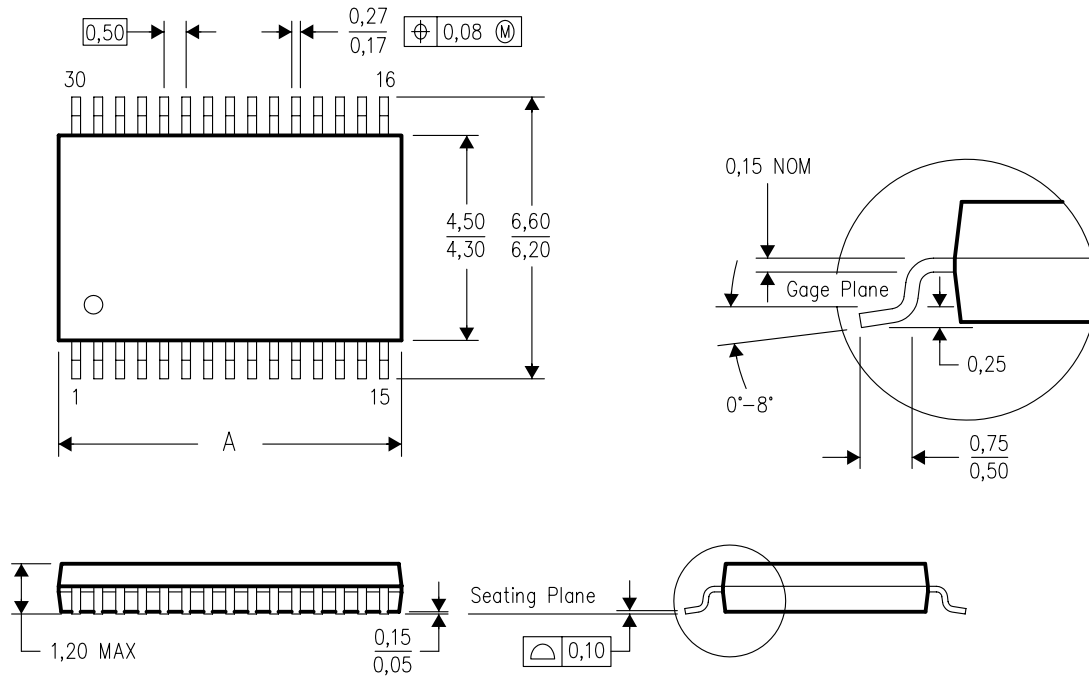

DIM \ PINS **	20	24	28	30	38	44	50
A MAX	5,10	6,60	7,90	7,90	9,80	11,40	12,60
A MIN	4,90	6,40	7,70	7,70	9,60	11,20	12,40

4073252/F 09/05

- NOTES:
- A. All linear dimensions are in millimeters.
 - B. This drawing is subject to change without notice.
 - C. Body dimensions do not include mold flash or protrusion.
 - D. Falls within JEDEC MO-153 except 44 pin package length.

IMPORTANT NOTICE

Texas Instruments Incorporated and its subsidiaries (TI) reserve the right to make corrections, modifications, enhancements, improvements, and other changes to its products and services at any time and to discontinue any product or service without notice. Customers should obtain the latest relevant information before placing orders and should verify that such information is current and complete. All products are sold subject to TI's terms and conditions of sale supplied at the time of order acknowledgment.

TI warrants performance of its hardware products to the specifications applicable at the time of sale in accordance with TI's standard warranty. Testing and other quality control techniques are used to the extent TI deems necessary to support this warranty. Except where mandated by government requirements, testing of all parameters of each product is not necessarily performed.

TI assumes no liability for applications assistance or customer product design. Customers are responsible for their products and applications using TI components. To minimize the risks associated with customer products and applications, customers should provide adequate design and operating safeguards.

TI does not warrant or represent that any license, either express or implied, is granted under any TI patent right, copyright, mask work right, or other TI intellectual property right relating to any combination, machine, or process in which TI products or services are used. Information published by TI regarding third-party products or services does not constitute a license from TI to use such products or services or a warranty or endorsement thereof. Use of such information may require a license from a third party under the patents or other intellectual property of the third party, or a license from TI under the patents or other intellectual property of TI.

Reproduction of information in TI data books or data sheets is permissible only if reproduction is without alteration and is accompanied by all associated warranties, conditions, limitations, and notices. Reproduction of this information with alteration is an unfair and deceptive business practice. TI is not responsible or liable for such altered documentation.

Resale of TI products or services with statements different from or beyond the parameters stated by TI for that product or service voids all express and any implied warranties for the associated TI product or service and is an unfair and deceptive business practice. TI is not responsible or liable for any such statements.

Following are URLs where you can obtain information on other Texas Instruments products and application solutions:

Products

Amplifiers	amplifier.ti.com
Data Converters	dataconverter.ti.com
DSP	dsp.ti.com
Interface	interface.ti.com
Logic	logic.ti.com
Power Mgmt	power.ti.com
Microcontrollers	microcontroller.ti.com
Low Power Wireless	www.ti.com/lpw

Applications

Audio	www.ti.com/audio
Automotive	www.ti.com/automotive
Broadband	www.ti.com/broadband
Digital Control	www.ti.com/digitalcontrol
Military	www.ti.com/military
Optical Networking	www.ti.com/opticalnetwork
Security	www.ti.com/security
Telephony	www.ti.com/telephony
Video & Imaging	www.ti.com/video
Wireless	www.ti.com/wireless

Mailing Address: Texas Instruments
Post Office Box 655303 Dallas, Texas 75265