

038391

The TUA 2000-4 is a monolithically integrated circuit and suitable as a tuner for the VHF range up to 400 MHz, e.g. for TV tuners.

RF section

- Few external components
- Stable oscillator frequency and amplitude with very low interference radiation
- Optimal rejection of oscillator and input frequencies at the IF output due to a decoupled active ring mixer circuit
- High interference voltage resistance
- High-impedance mixer input, for symmetrical and asymmetrical connections
- IF post-amplifier for the UHF IF signal

IF section

- Optimal cross-talk rejection
- Large signal-modulation range
- Low noise figure with wide minimum over large load-impedance range

Maximum ratings

Supply voltage range $V_3 \leq V_S$	V_S	-0.3 to 16.5	V
Reference voltage $V_S \geq V_3$	V_3	-0.3 to 8.3	V
Voltage at pin 1, 2 $V_3 \leq V_{1,2}$	$V_{1,2}$	-0.3 to 16.5	V
Voltage at pin 8, 9 $V_3 \leq V_{8,9}$	$V_{8,9}$	-0.3 to 16.5	V
Voltage at pin 14 $V_{14} \leq V_S$	V_{14}	-0.3 to 16.5	V
AC voltage at pin 4, 5, 6, 11, 12, 13, 15	V_{rms}	0 to 0.5	V
Junction temperature	T_j	150	°C
Storage temperature range	T_{stg}	-40 to 125	°C
Thermal resistance (system-air)	$R_{th SA}$	80	K/W

Only the specified external circuitry may be applied to pins 4, 5, 6, 11, 12, 13, 15.

Operating range

Supply voltage	V_S	9 to 15	V
Reference voltage	V_3	7.2 to 8.2	V
Input frequency – mixer section	$f_{M12/13}$	10 to 400	MHz
Input frequency of the UHF IF amplifier	f_{UHF11}	10 to 400	MHz
Input frequency of the SAW amplifier	f_{IF15}	10 to 400	MHz
Oscillator amplifier depending on the oscillator circuitry at pin 4, 5	$f_{OSC4,5}$	10 to 400	MHz
Voltage at pin 1, 2, 8, 9	$V_{1,2,8,9}$	9 to 15	V
Output frequency of the mixer/UHF	$f_{IFM/UHF8/9}$	10 to 400	MHz
Output frequency of the SAW amplifier	$f_{IF1,2}$	10 to 400	MHz
Ambient temperature	T_A	0 to 70	°C

Characteristics $V_S = 12\text{ V}; V_3 = 7.5\text{ V}; T_A = 25\text{ }^\circ\text{C}$

		min	typ	max	
Total current consumption	$I_{10,1,2,8,9,3}$				
$I_{14} = 0; V_3 = 7.2\text{ V}; V_S = 9\text{ V}$		37	49	60	mA
$I_{14} = 0; V_S = 12\text{ V}$		40	52	64	mA
Current consumption at pin 3	I_3	14	19	25	mA
$I_{14} = 0$					
Output characteristic	$\Delta I_{8,9}$			100	μA
$V_{8,9} = 9\text{--}15\text{ V}; V_3 = 7.8\text{ V}$					
Output characteristic	$\Delta I_{1,2}$			200	μA
$V_{1,2} = 9\text{--}15\text{ V}; V_3 = 7.8\text{ V}$					
UHF switching voltage	$V_{14\text{ UHF}}$	7		V_S	V
$V_{I(u)} = -25\text{ dBm}$					
$V_Q \geq -5\text{ dBm}; f_{IF} = 36.15\text{ MHz}$					
VHF switching voltage	$V_{14\text{ VHF}}$	0		3	V
$V_{I(u)} = -25\text{ dBm}$					
$V_Q \leq -30\text{ dBm}; f_{IF} = 36.15\text{ MHz}$					
Mixer gain	G_{60}	25	27	29	dB
Bd I; $V_{I(RF)} = -40\text{ dBm};$					
$f_{RF} = 60\text{ MHz}; f_{IF} = 36.15\text{ MHz};$					
$R_{G12/13} = 100\ \Omega;$					
refer to response characteristic page 750					
Mixer gain	G_{220}	25	27	29	dB
Bd III; $V_{I(RF)} = -40\text{ dBm};$					
$f_{IF} = 36.15\text{ MHz}; R_{G12/13} = 100\ \Omega;$					
refer to response characteristic page 751					
Mixer noise	NF_{60}			13	dB
Bd I, white noise					
$R_{G12/13} = 100\ \Omega;$ refer to response characteristic page 750					
Mixer noise	NF_{220}			14	dB
Bd III; white noise					
$R_{G12/13} = 100\ \Omega;$ refer to response characteristic page 751					
Gain UHF input	V_{UHF}	31	33	35	dB
$V_{I(u)} = -40\text{ dBm}; V_{14} = V_S = 12\text{ V}$					
$f_{RFU} = f_{IF} = 36.15\text{ MHz};$					
$R_{G11} = 200\ \Omega;$ refer to response characteristic page 751					
Noise figure UHF input	NF_{UHF}			7	dB
$V_{14} = V_S = 12\text{ V};$ white noise					
$R_{G11} = 200\ \Omega;$ refer to response characteristic page 751					
Oscillator turn-on drift	f_{OSC}	-10		-250	kHz
$V_D = 28\text{ V}; t = 0\text{--}500\text{ ms};$					
Bd II; $f_{OSC} = 216\text{ MHz}$					
Oscillator turn-on drift	f_{OSC}	-10		-450	kHz
$V_D = 28\text{ V}; t = 0\text{--}10\text{ s};$					
Bd II; $f_{OSC} = 216\text{ MHz}$					

	min	typ	max	
Additional application data				
Differential input resistance ¹⁾		3		kΩ
Differential input capacitance ¹⁾		2.7		pF
IF input resistance ¹⁾		2		kΩ
IF input capacitance ¹⁾		3.9		pF
UHF input resistance ¹⁾		2.2		kΩ
UHF input capacitance ¹⁾		3.4		pF
Interference voltage resistance Bd I ²⁾		38		mV
$m_N = 1\%$; $m_{int} = 80\%$; $f_{int} = f_N \pm 15$ MHz $f_{mod} = 1$ kHz; $f_N = 65$ MHz refer to response characteristic				
Interference voltage resistance Bd II ²⁾		30		mV
$m_N = 1\%$; $m_{int} = 80\%$; $f_{int} = f_N \pm 15$ MHz $f_{mod} = 1$ kHz; $f_N = 220$ MHz refer to response characteristic				

Note on characteristics

Due to quasi no-load of the transformer output and $2 \times 50 \Omega$ source impedance, the interference voltage at pins 12/13 is calculated by

$$V_{int12/13} \approx V_{int(source/2)} \times 2 \times \sqrt{2}$$

¹⁾ Measured S parameter values converted to Y parameters

²⁾ See: Measurement configuration to measure cross modulation

Circuit description

The TUA 2000-4 contains a symmetrical mixer input, as well as a multiplicative mixer. The oscillator amplitude is regulated. All oscillator operating currents and voltages are stabilized, so that the oscillator's amplitude and frequency are largely independent of temperature and operating voltage changes.

The IF amplifier has been provided with a high impedance input.

The output has two open collector connections.

During UHF operation, oscillator and mixer are switched off and the UHF IF input coupling stage is activated.

RF section

- Few external components
- Stable oscillator frequency and amplitude with very low interference radiation
- Optimal rejection of oscillator and input frequencies at the IF output due to a decoupled active ring mixer circuit
- High interference voltage resistance
- High-impedance mixer input, for symmetrical and asymmetrical connections
- IF post-amplifier for the UHF IF signal

IF section

- Optimal cross-talk rejection
- Large signal-modulation range
- Low noise figure with wide minimum over large load-impedance range

Plug-in location plan

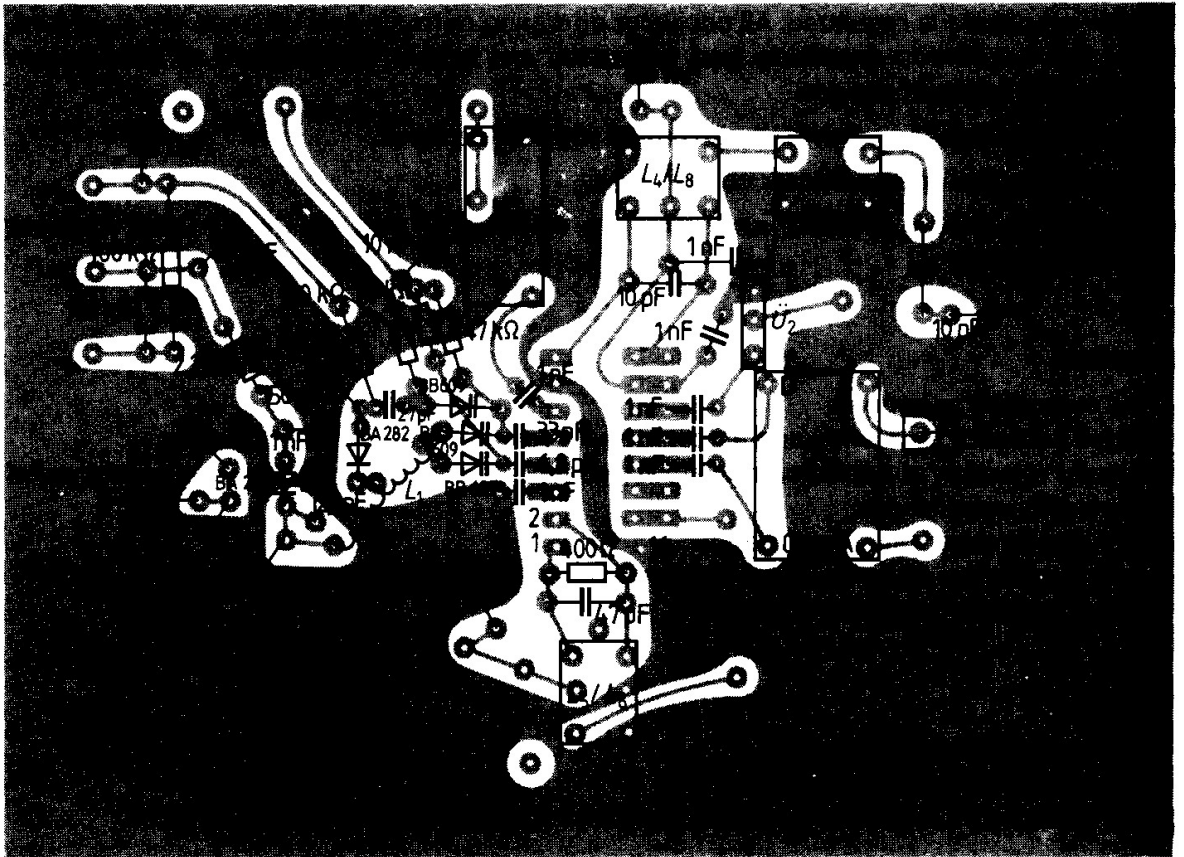

PCB layout of test and measurement circuit 1

Block diagram

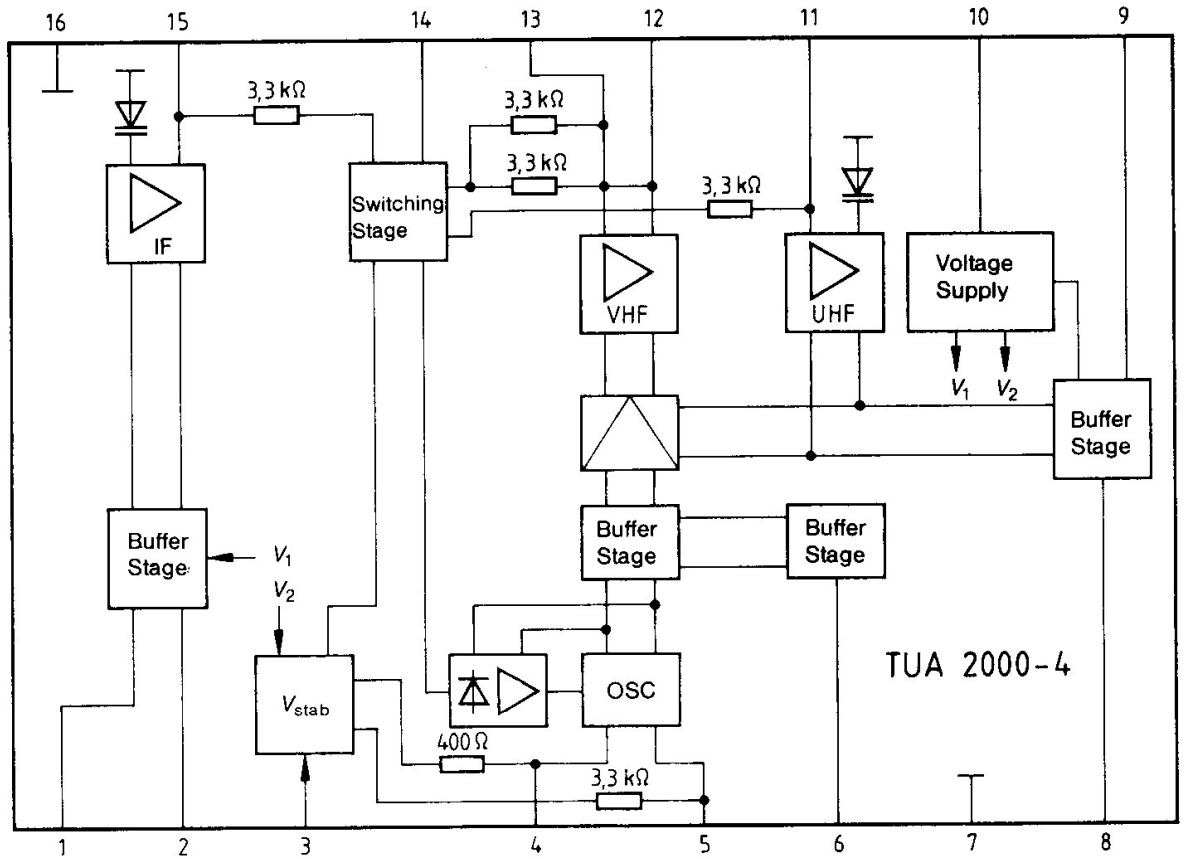

Pin description

Pin	Function
1	“Open collector” output of the IF SAW driver
2	“Open collector” output of the IF SAW driver
3	Input for external reference voltage
4	Low-ohmic collector output to the high reference point of a parallel resonant circuit
5	High-ohmic base input to the high reference point of a parallel resonant circuit
6	Oscillator signal output for counter connection
7	GND
8	“Open collector” output of the mixer
9	“Open collector” output of the mixer
10	Supply voltage
11	Asymmetrical IF signal input for the UHF IF signal
12	Mixer high-impedance differential input
13	Mixer high-impedance differential input
14	Switching voltage input for the VHF-UHF switch selection
15	Asymmetrical signal input of the IF SAW amplifier
16	GND

Test and measurement circuit 1

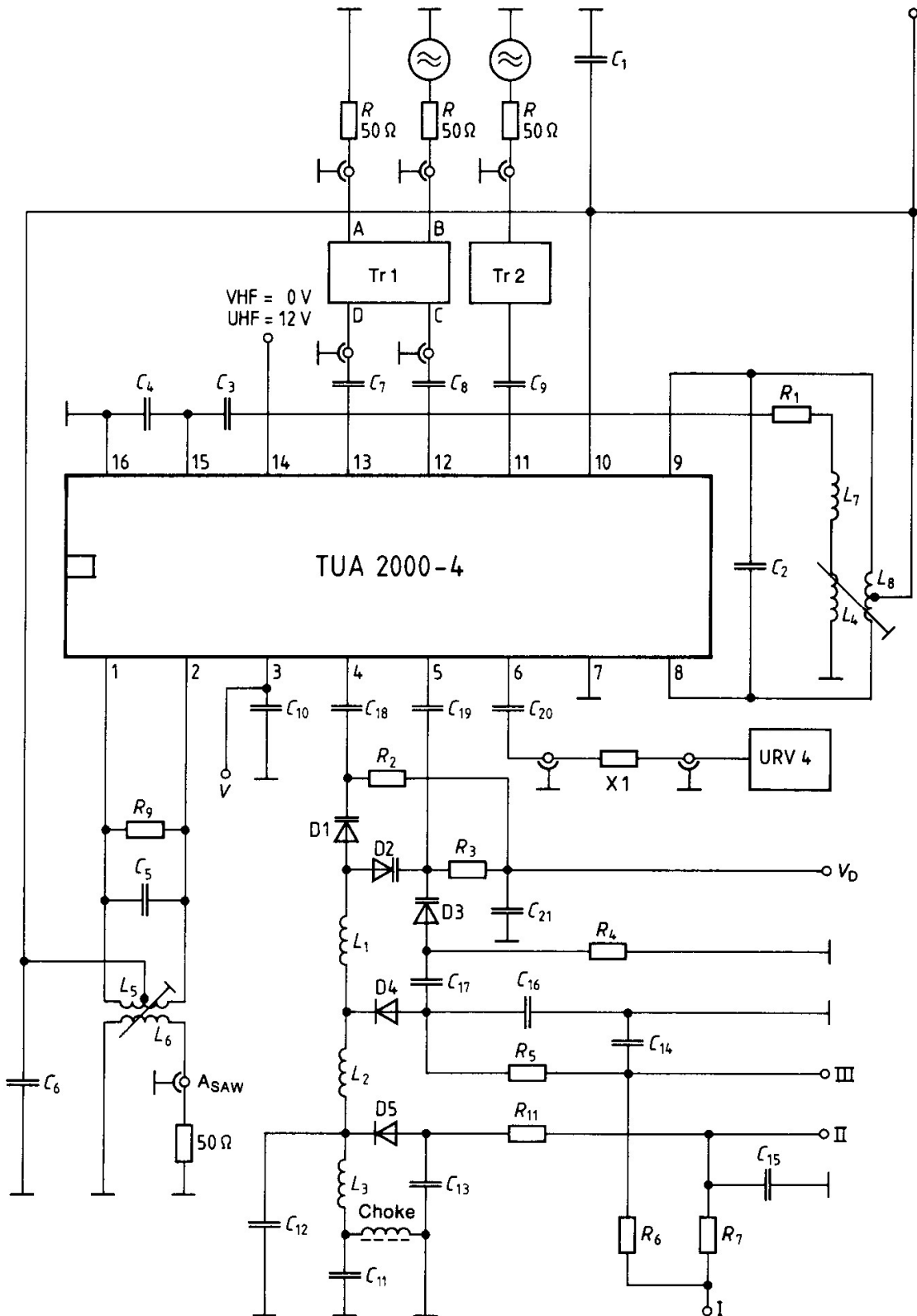

Notes on test and measurement circuit 1

Response of passband curve for operation in VHF band I

$f_{RF} = 60 \text{ MHz} \pm 10 \text{ MHz}$; $V_{14} = 0 \text{ V}$; $V_{I(REF)} = -40 \text{ dBm}$; ref. level = -10 dBm

gain test point $f_{RF} = 60 \text{ MHz}$; $f_{IF} = 36.15 \text{ MHz}$

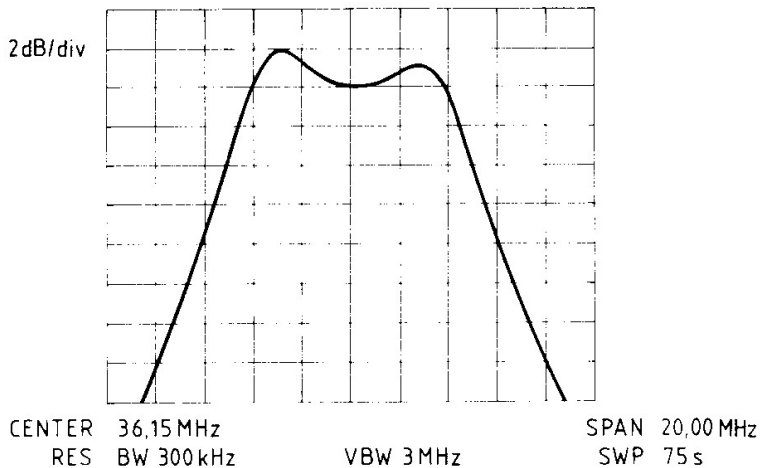

Explanations to diagrams

- 2 dB/div = 2 dB/division of Y axis
- Center 36.15 MHz = center frequency of display at IF = 36.15 MHz
- RES BW 300 kHz = resolution bandwidth of spectrum analyzer is 300 kHz in its IF section
- VBW 3 MHz = video bandwidth in IF section of spectrum analyzer is 3 MHz
- SPAN 20.00 MHz = overall display range of diagram is 20 MHz, i.e. 2 MHz/division on X axis
- SWP 75 = sweep time on X axis is 75 s
- Ref. level = reference level is top horizontal line of diagram

Notes on test and measurement circuit 1

Response of passband curve for operation in VHF band III

$f_{RF} = 220 \text{ MHz} \pm 10 \text{ MHz}$; $V_{14} = 0 \text{ V}$; $V_{1(RF)} = -40 \text{ dBm}$; ref. level = -10 dBm
 gain test point $f_{RF} = 220 \text{ MHz}$; $f_{IF} = 36.15 \text{ MHz}$

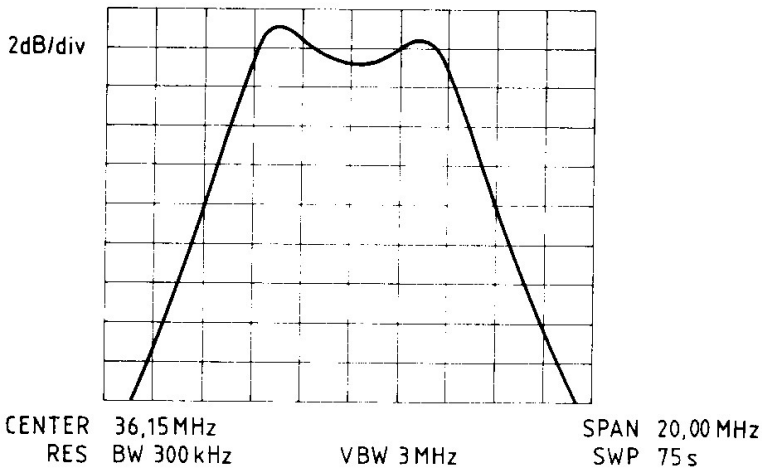

Response of passband curve for operation in VHF IF position

$f_{RFU} = 36.15 \text{ MHz} \pm 10 \text{ MHz}$; $V_{14} = 12 \text{ V}$; $V_{1(RF)} = -40 \text{ dBm}$; ref. level = 0 dBm
 gain test point $f_{RFU} = f_{IF} = 36.15 \text{ MHz}$

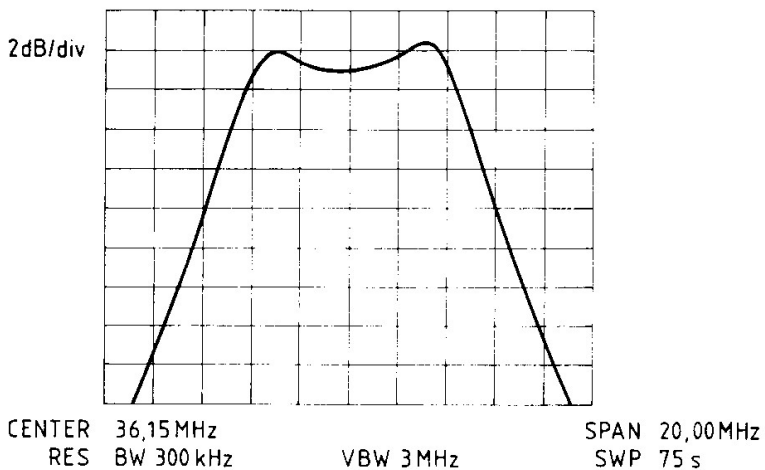

Notes on test and measurement circuit 1

Between pin 4 – C18 – D1 – D2 – C19 – pin 5 ensure minimal lead inductance for the suppression of parasitic series resonance outside the oscillator's useful band.

Transformer Tr 1:

Tr 1 = anzac = HH-109 30 to 500 MHz
 $C = 0^\circ; R_{gC} = 50 \Omega$
 $D = 180^\circ; R_{gD} = 50 \Omega$

Transformer Tr 2:

50/200 Ω unbalanced
 3 turns bifilar on core material
 B62152-A7-X1

Attenuator: X1 = 6 dB

Bd I 58 to 85 MHz
 Bd II 110 to 216 MHz
 Bd III 200 to 400 MHz

	I	II	III
Band I	-12 V	X	X
Band II	-12 V	+12 V	X
Band III	-12 V	+12 V	+12 V

Notes on test and measurement circuit 1

Part list

Resistors:

R_1	—	10	Ω
R_2	—	47	k Ω
R_3	—	47	k Ω
R_4	—	10	k Ω
R_5	—	2.2	k Ω
R_6	—	100	k Ω
R_7	—	100	k Ω
R_8	—	100	k Ω
R_9	—	400	Ω
R_{11}	—	2.2	k Ω

Capacitors:

C_1	—	1	nF	Chip capacitor
C_2	—	15	pF	STYROFLEX
C_3	—	1	nF	STYROFLEX
C_4	—	10	pF	STYROFLEX
C_5	—	47	pF	STYROFLEX
C_6	—	1	nF	Chip capacitor
C_7	—	1	nF	Chip capacitor
C_8	—	1	nF	Chip capacitor
C_9	—	1	nF	Chip capacitor
C_{10}	—	10	nF	Chip capacitor
C_{11}	—	82	pF	Chip capacitor
C_{12}	—	2.2	pF	Chip capacitor
C_{13}	—	1	nF	Chip capacitor
C_{14}	—	1	nF	Chip capacitor
C_{15}	—	1	nF	Chip capacitor
C_{16}	—	150	pF	Chip capacitor (Trapezoidal cap.)
C_{17}	—	27	pF	Chip capacitor (Chip capacitor)
C_{18}	—	6.8	pF	Chip capacitor (Chip capacitor)
C_{19}	—	33	pF	Chip capacitor (Chip capacitor)
C_{20}	—	1	nF	Chip capacitor
C_{21}	—	10	nF	Chip capacitor

Diodes:

D1	—	BB 505 G
D2	—	BB 609
D3	—	BB 609
D4	—	BA 282
D5	—	BA 282
D6	—	BZX 97 C 75 V

IC:

TUA 2000-4

Coils:

L_1	—	4 turns; core \varnothing 2 mm; wire \varnothing 0.5 mm; CuL
L_3	—	5 turns; core \varnothing 4 mm; wire \varnothing 0.5 mm; CuL
L_3	—	9 turns; core \varnothing 4 mm; wire \varnothing 0.5 mm; CuL
L_1, L_2, L_3	—	air-core coils
L_4	—	2.5 turns; CuLs wire \varnothing 0.25 mm
L_8	—	2*6 turns; CuLs wire \varnothing 0.25 mm
L_7	—	15 turns; CuLs wire \varnothing 0.25 mm
L_5	—	2*4.5 turns; CuLs wire 0.25 mm
L_6	—	3 turns; CuLs wire \varnothing 0.25 mm
	—	Coil formers of $L_4/L_8, L_7, L_5/L_6$
	—	Vogt filter set 10*12
	—	5140500000
	—	Catalog p. 41-8

Chokes:

Ch — 10 μ H

Please note that the chip capacitors may be damaged if the board is subjected to mechanical stress; thus overall functioning can no longer be guaranteed.

During the operating mode the PC board is adjusted without the socket. When the socket is inserted in the socket connector, the parameters for the oscillator frequency and amplitude as well as gain and noise will change.

Test and measurement circuit 2

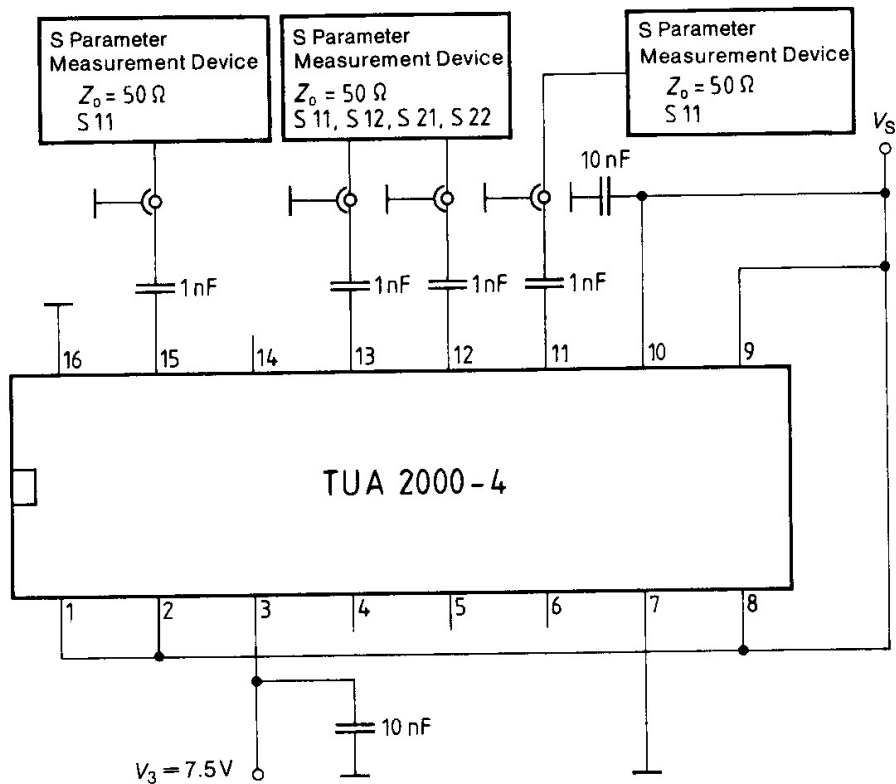

For the determination of the input admittance values of pins 11, 12, 13, 15

Application circuit 1

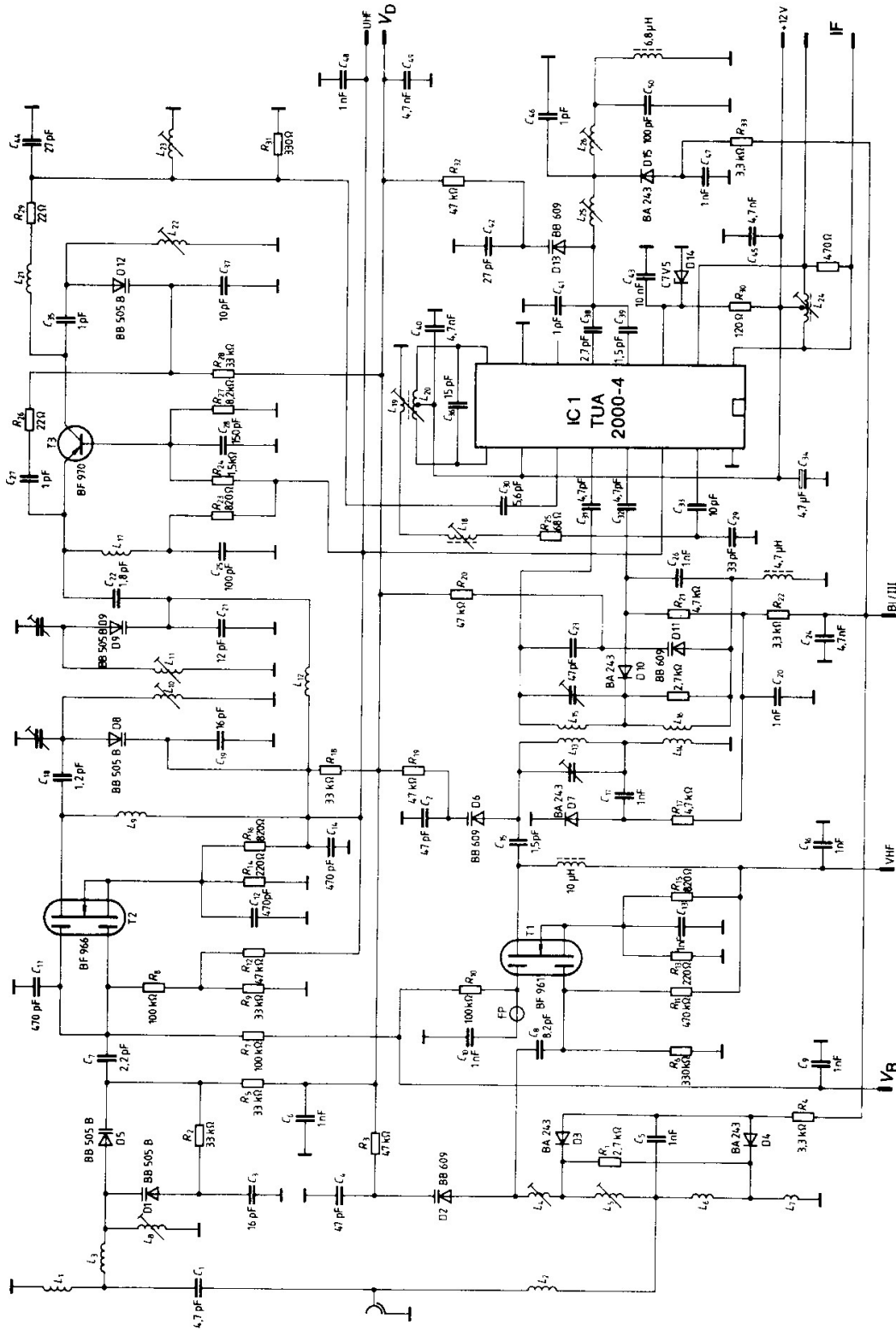

Application circuit 2

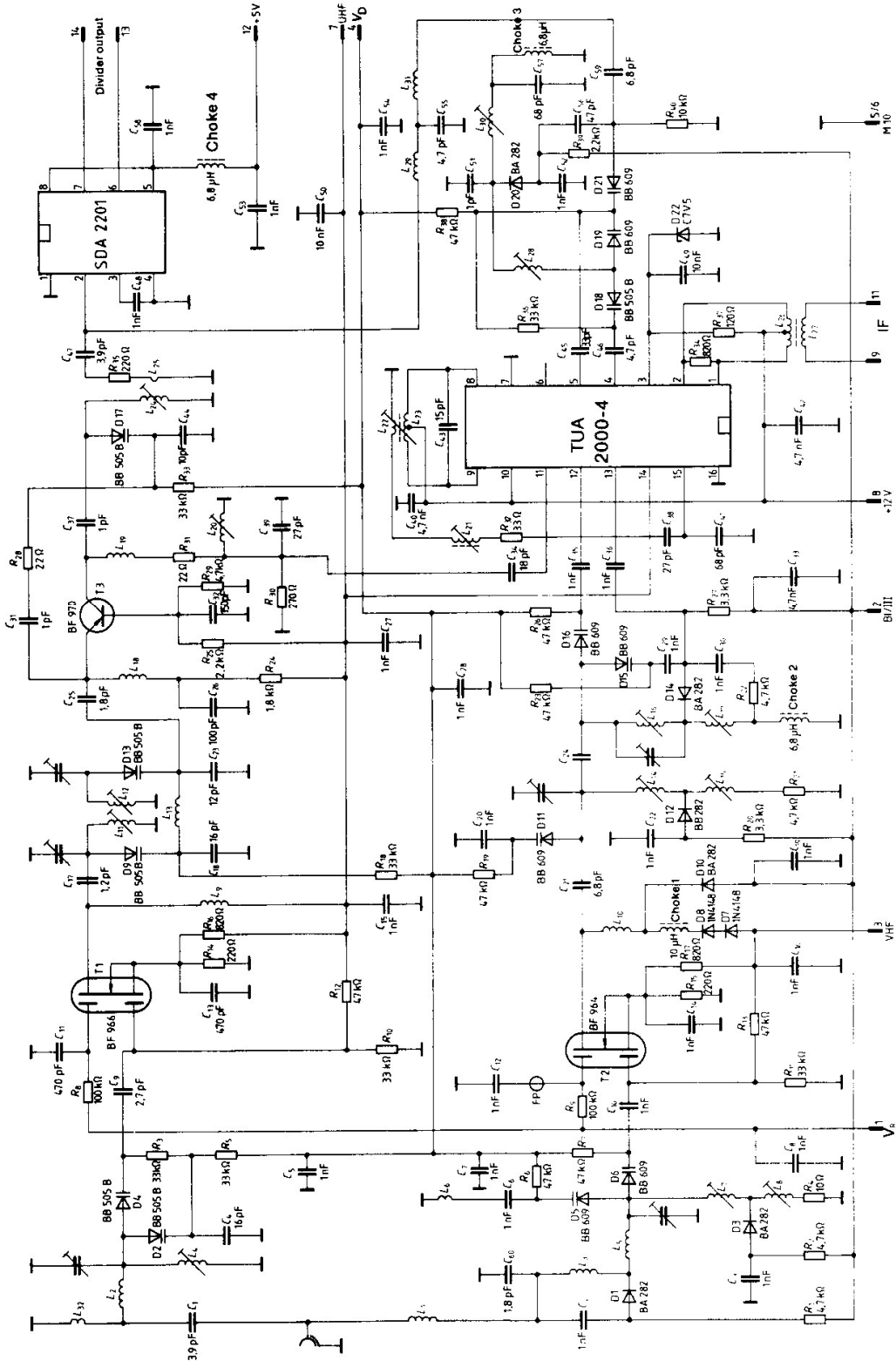

Test and measurement circuit 3

Measurement configuration to measure cross modulation

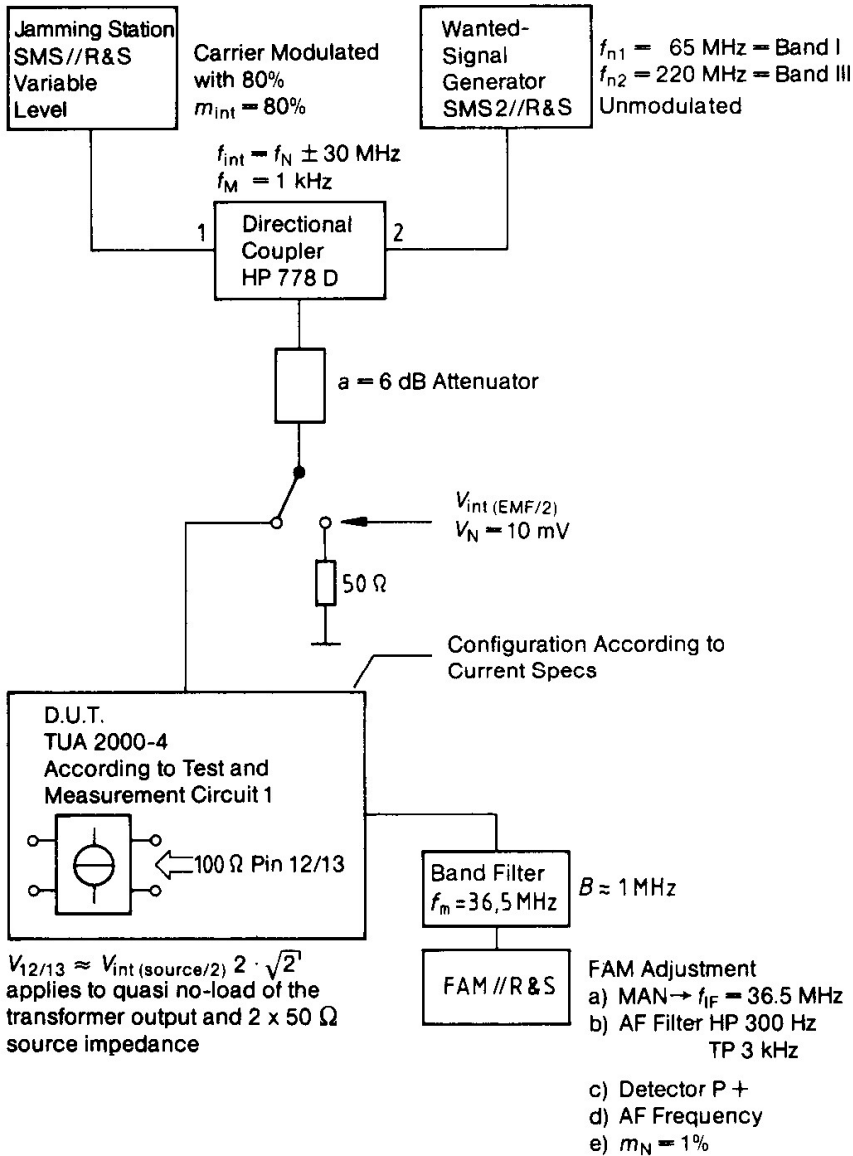

Interference voltage for 1% cross modulation

$V_{int} = EMF/2; m_{int} = 80\%$

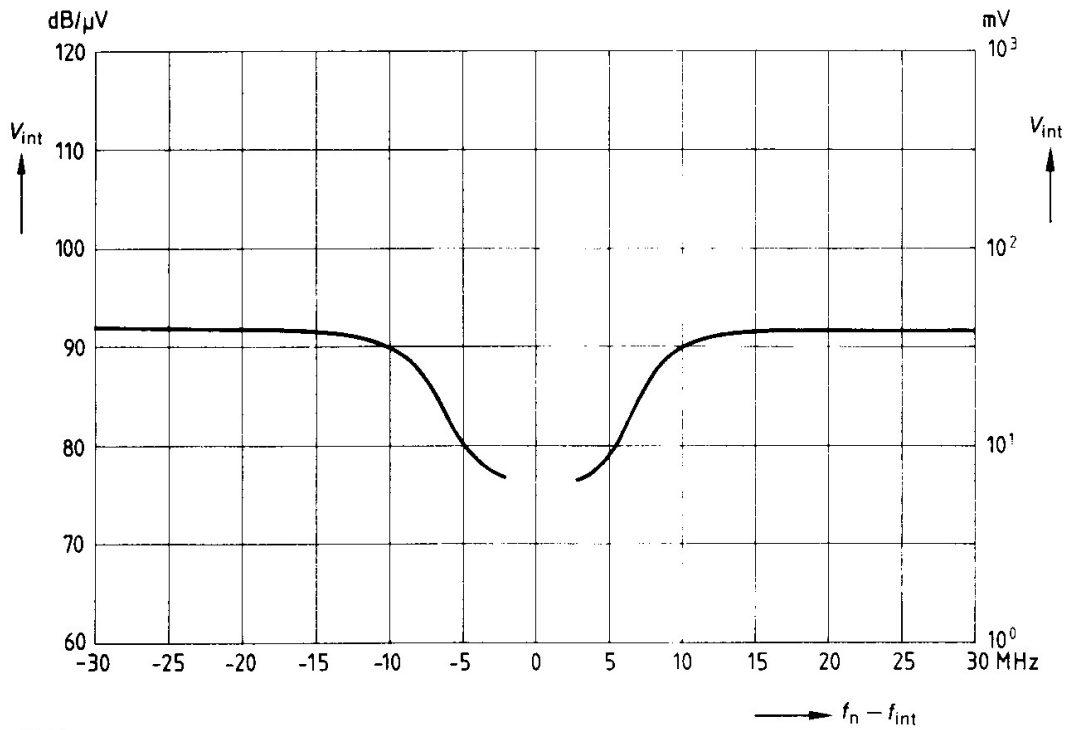

Bd I

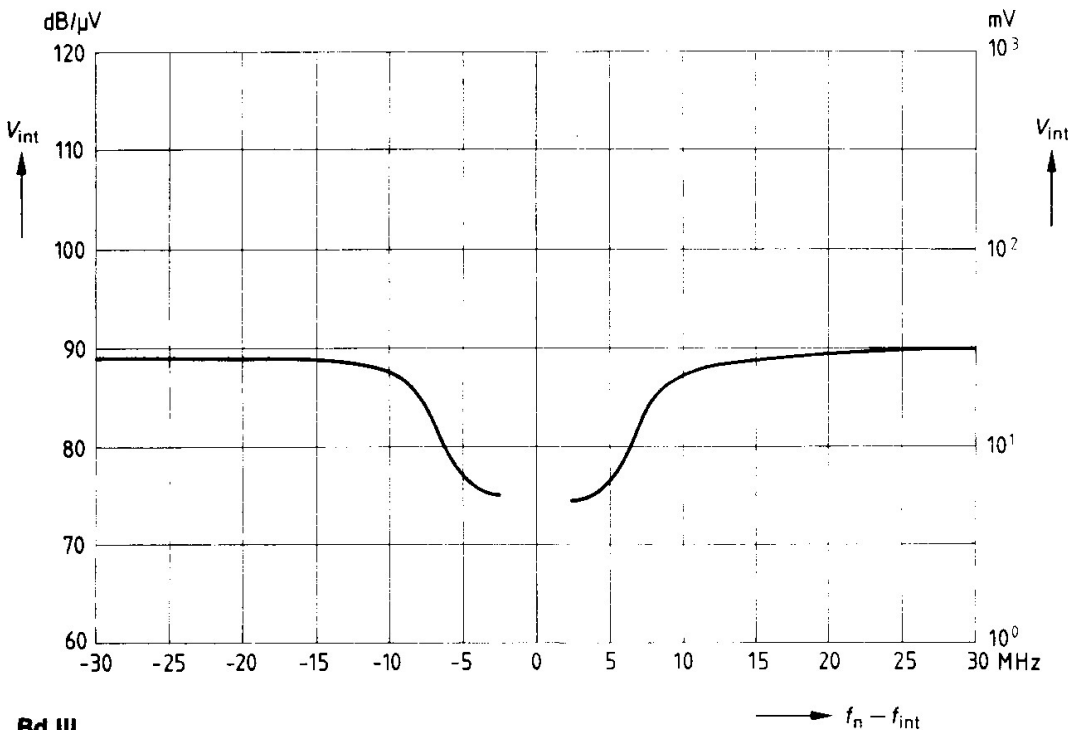

Bd III