

Mini power relay K (open and sealed)



Description

Features

- 60% smaller volume than power relay K
- High switching capacity
- Small footprint, minimal space requirements

Typical applications

- Lamp control circuits
- Indicator control circuits
- Sunroof motors
- Window motors
- Immobilizers
- Central doorlock etc.
- Also available for 42 V applications

Please contact Tyco Electronics for relay application support.

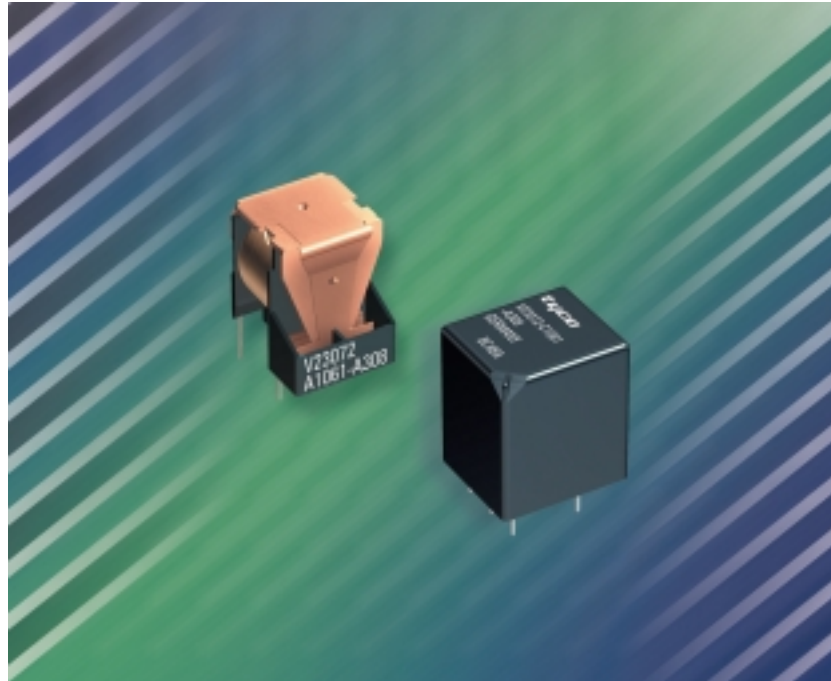

~~Car Industry~~



Truck Industry



~~Other Industry~~

72A_3d01 / 72C_3d01

Design

Open or sealed;
sealed version: sealing in accordance with IEC 68;
immersion cleanable: protection class IP 67 to IEC 529 (EN 60 529)

Weight

Approx. 0.28 oz. (8 g) open version
Approx. 0.32 oz. (9 g) sealed version

Nominal voltage

12 V or 24 V;
other nominal voltages on request

Terminals

PCB terminals, for assembling in printed circuit boards
Terminals in grid 0.049 ... 0.050" (1.25 ... 1.27 mm)

Conditions

All parametric, environmental and endurance tests are performed according to EIA Standard RS-407-A at standard test conditions unless otherwise noted:
23 °C ambient temperature, 20-50% RH, 29.5 ± 1.0" Hg (998.9 ± 33.9 hPa).
Please also refer to the Application Recommendations in this catalog for general precautions.

Disclaimer

All technical performance data apply to the relay as such, specific conditions of the individual application are not considered. Please always check the suitability of the relay for your intended purpose. We do not assume any responsibility or liability for not complying herewith. We recommend to complete our questionnaire and to request our technical service. Any responsibility for the application of the product remains with the customer only. All specifications are subject to change without notification. All rights of Tyco are reserved.

Mini power relay K (open)

Dimensional drawing

Open version

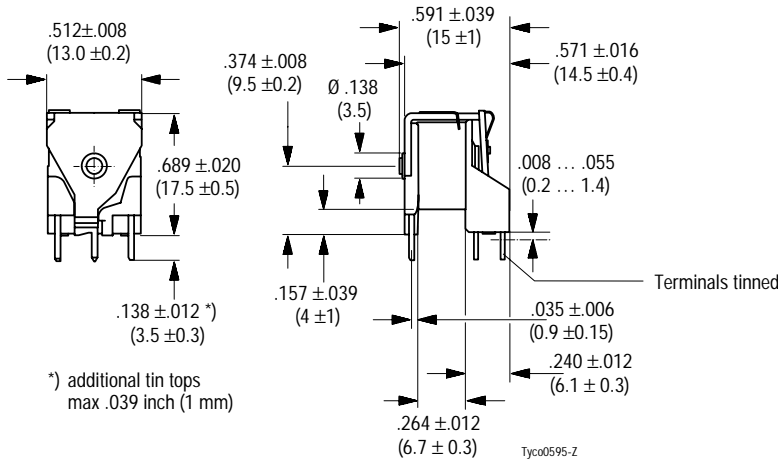

View of the terminals (Bottom view)

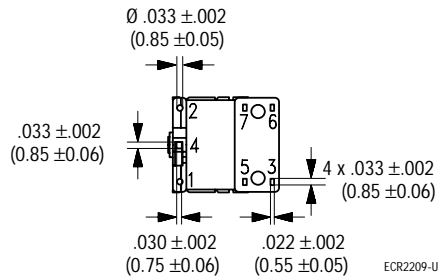

Mounting holes

View of the terminals (Bottom view)

Grid 0.049 ... 0.050" (1.25 ... 1.27 mm)

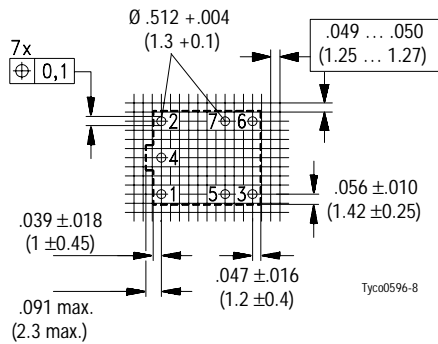

Mini power relay K (sealed)

Dimensional drawing

Sealed version

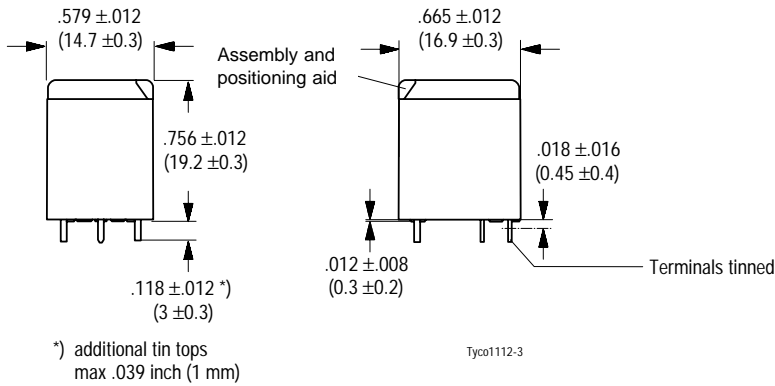

View of the terminals (Bottom view)

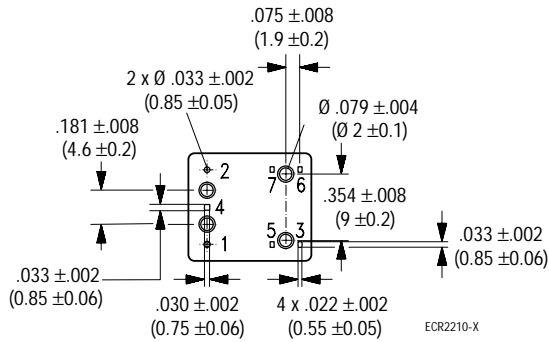

Mounting holes

View of the terminals (Bottom view)

Grid 1.25 ... 1.27 mm

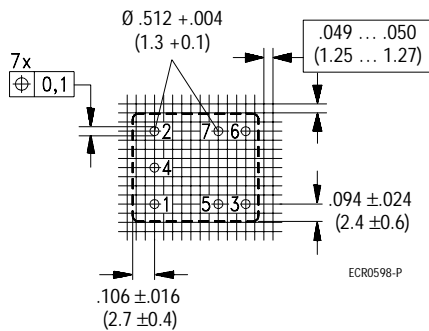

Mini power relay K (open and sealed)

Contact data					
Typical areas of application	Resistive / inductive loads			Indicator lamps	
Contact configuration	Make contact/ Form A	Changeover contact/ Form C	Double make contact/ Form U	Make contact/ Form A	Double make contact/ Form U
Circuit symbol (see also Pin assignment)					
Rated voltage	12 V				
Rated current at 85 °C	10 A	5 A/10 A	2 x 6 A	5 A	2 x 5 A
Contact material	AgNi0.15			AgSnO ₂	
Max. switching voltage/power	See load limit curve				
Max. switching current ¹⁾					
On ²⁾	60 A	NC/NO 12 A/60 A	2 x 40 A	60 A ³⁾	120 A ³⁾
Off	20 A	10 A/20 A	2 x 20 A	6 A	12 A
Min. recommended load ⁵⁾	1 A at 5 V				
Voltage drop at 10 A (initial) for NC/NO contacts	Typ. 50 mV, 300 mV max.		Typ. 2 x 50 mV, 300 mV max.		Typ. 150 mV, 300 mV max.
Mechanical endurance (without load)	> 10 ⁷ operations				
Electrical endurance (example of resistive load)	> 2 x 10 ⁵ operations 10 A, 13.5 V			> 1,5 x 10 ⁶ operations up to 3 x 21 W	> 1,5 x 10 ⁶ operations up to 6 x 21 W

¹⁾ The values apply to a resistive load or inductive load with suitable spark suppression.

²⁾ For a load current duration of maximum 3 s for a make/break ratio of 1:10.

³⁾ Corresponds to the peak inrush current on initial actuation (cold filament).

⁴⁾ At 50 % ON period

⁵⁾ See chapter Diagnostics in our Application Recommendations on page 18.

Load limit curve

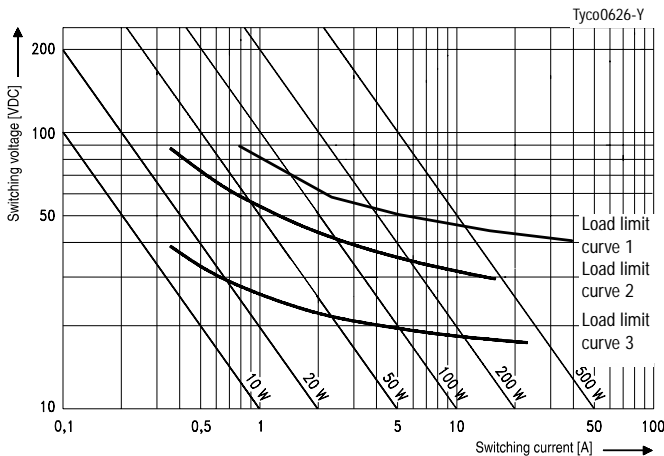

Load limit curve 1 ≙ safe shutdown, connected as form X, load on pin 5 and 7

Load limit curve 2 ≙ safe shutdown, no stationary arc / make contact

Load limit curve 3 ≙ arc extinguishes during transit time (changeover contact)

Pin assignment (open and sealed)

1 make contact/
1 form A

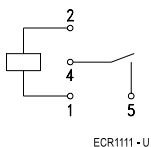

1 double make contact/
1 form U

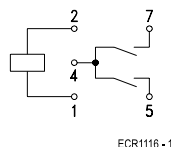

1 changeover contact/
1 form C

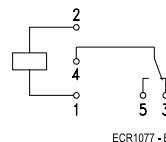

Mini power relay K (open and sealed)

Coil data

Available for nominal voltages	12, 24 V (other coils on request)
Nominal power consumption of the unsuppressed coil at nominal voltage	1.1 W
Test voltage winding/contact	500 VAC _{rms}
Maximum ambient temperature range ¹⁾	- 40 to + 85 °C
Operate time at nominal voltage ²⁾	Typ. 3 ms
Release time at nominal voltage	Typ. 1.5 ms

¹⁾ See also operating voltage range diagram

²⁾ Measured at nominal voltage without coil suppression unit

N.B.

A low resistive suppression device in parallel to the relay coil increases the release time and reduces the lifetime caused by increased erosion and/or higher risk of contact tack welding.

Operating voltage range

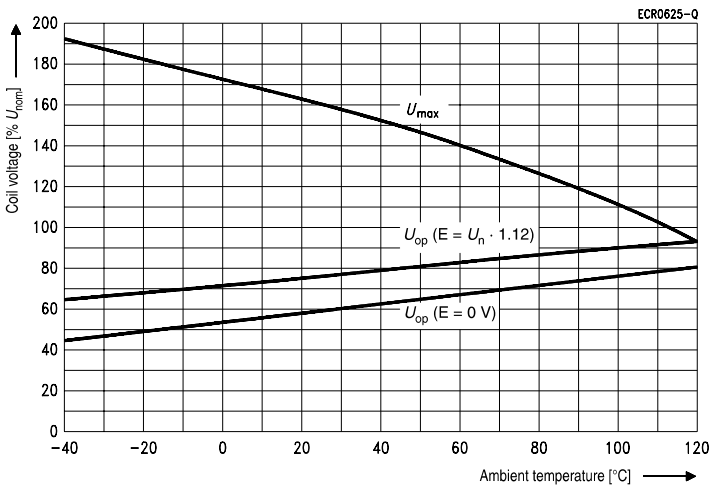

Does not take into account the temperature rise due to the contact current
E = pre-energization

Mechanical data

Enclosure	Sealed relay is suitable for immersion cleaning of PCB assembly or conformal coating.
Sealed	Please refer to the Application Recommendations in this catalog.

Operating conditions

Temperature range, storage	-40 °C to 155 °C			
Test	Relevant standard	Testing as per	Dimension	Comments
Climatic cycling with condensation ¹⁾	EN ISO 6988		20 cycles	Storage 8/16 h
Temperature cycling ¹⁾	IEC 68-2-14	Na	20 cycles	- 40/+ 85 °C (dwell time 1 h)
Damp heat ¹⁾				
constant	IEC 68-2-3	Ca	56 days	Upper air temperature 55 °C
Corrosive gas ¹⁾	IEC 68-2-42 IEC 68-2-43	-	10 days 10 days	
Vibration resistance	IEC 68-2-6 (sine pulse form) acceleration, acc. to position		10 ... 200 Hz 23 ... 35 g	No change in the switching state > 10 μs
Shock resistance	IEC 68-2-27 (half-sine pulse form) acceleration		4 ... 6 ms 23 ... 280 g	No change in the switching state > 10 μs
Solderability	IEC 68-2-20	Ta, Method 1		Aging 3 (4 h/155 °C) Dewetting
Resistance to soldering heat	IEC 68-2-20	Tb, Method 1A		10 s ± 1 s with thermal screen
Sealing ¹⁾	IEC 68-2-17	Qc, Method 2		1 min / 70 °C
Flammability	UL94-HB			

¹⁾ only sealed version

Mini power relay K (open and sealed)

Ordering information

Part numbers (see table below for coil data)		Contact arrangement	Contact material	Enclosure	Terminals
Relay part number	Tyco order number				
V23072-A1061-A303	3-1393272-2	Form C	AgNi0.15	Open	Printed circuit
V23072-A1062-A303	5-1393272-2	Form C	AgNi0.15	Open	Printed circuit
V23072-A1061-A308	3-1393272-6	Form U, X	AgNi0.15	Open	Printed circuit
V23072-A1062-A308	5-1393272-3	Form U, X	AgNi0.15	Open	Printed circuit
V23072-C1061-A302	4-1393273-9	Form A	AgNi0.15	Sealed	Printed circuit
V23072-C1062-A302	7-1393273-6	Form A	AgNi0.15	Sealed	Printed circuit
V23072-C1061-A303	5-1393273-0	Form C	AgNi0.15	Sealed	Printed circuit
V23072-C1062-A303	7-1393273-8	Form C	AgNi0.15	Sealed	Printed circuit
V23072-C1061-A308	6-1393273-0	Form U, X	AgNi0.15	Sealed	Printed circuit
V23072-C1062-A308	8-1393273-2	Form U, X	AgNi0.15	Sealed	Printed circuit
V23072-C1061-A402	2-1416001-0	Form A	AgSn02	Sealed	Printed circuit
V23072-C1061-A408	1-1416001-4	Form U, X	AgSn02	Sealed	Printed circuit

Coil versions

Coil data for Mini K	Rated coil voltage (V)	Coil resistance +/- 10% (Ω)	Must operate voltage (V)	Must release voltage (V)	Allowable overdrive ¹⁾ voltage (V)		
					at 23 °C	at 85 °C	
Open and sealed	V23072-**061-****	12	130	6.9	1.2	19.2	14.9
	V23072-**062-****	24	520	14.1	2.4	38.4	29.8

¹⁾ Allowable overdrive is stated with no load applied and minimum coil resistance.

Standard delivery packs (orders in multiples of delivery pack)

Mini K open: 600 pieces
Mini K sealed: 504 pieces