



8K × 8 CMOS STATIC RAM

GENERAL DESCRIPTION

The W2465 is a slow-speed, low-power CMOS static RAM organized as 8192 × 8 bits that operates on a single 5-volt power supply. This device is manufactured using Winbond's high performance CMOS technology.

FEATURES

- Low power consumption:
 - Active: 250 mW (max.)
 - Standby: 100 μW (max.)(LL-version)
250 μW (max.)(L-version)
- Access time: 70/100 nS (max.)
- Single +5V power supply
- Fully static operation
- All inputs and outputs directly TTL compatible
- Three-state outputs
- Battery back-up operation capability
- Data retention voltage: 2V (min.)
- Available packages: 28-pin 600 mil DIP, 330 mil SOP and 300 mil skinny DIP

PIN CONFIGURATION

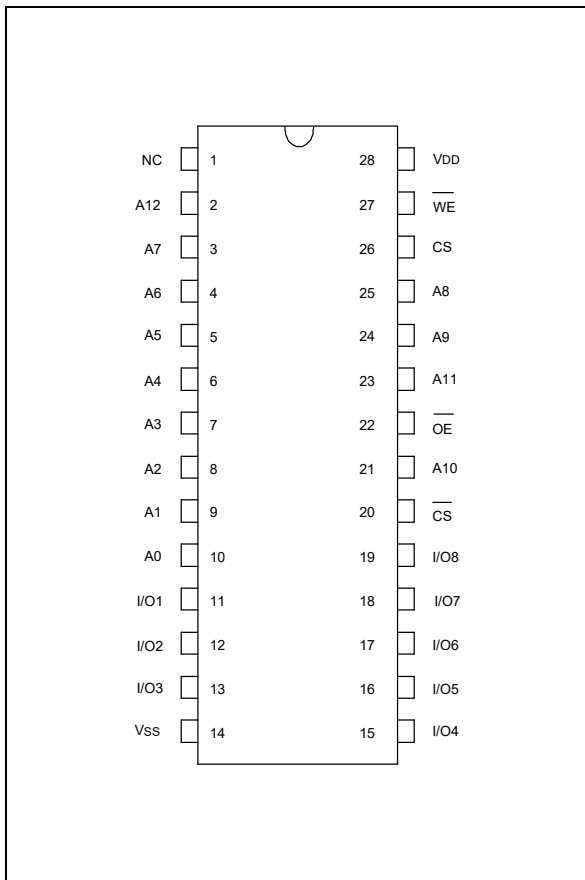

BLOCK DIAGRAM

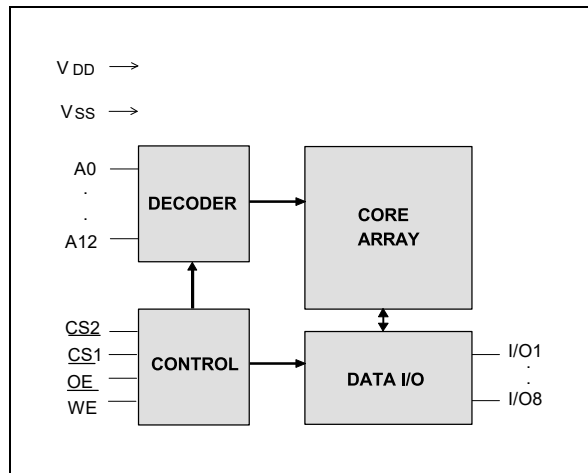

PIN DESCRIPTION

SYMBOL	DESCRIPTION
A0–A12	Address Inputs
I/O1–I/O8	Data Inputs/Outputs
CS1, CS2	Chip Select Inputs
WE	Write Enable Input
OE	Output Enable Input
VDD	Power Supply
VSS	Ground
NC	No Connection

TRUTH TABLE

CS1	CS2	OE	WE	MODE	I/O1-I/O8	V _{DD} CURRENT
H	X	X	X	Not Selected	High Z	I _{SB} , I _{SB1}
X	L	X	X	Not Selected	High Z	I _{SB} , I _{SB1}
L	H	H	H	Output Disable	High Z	I _{DD}
L	H	L	H	Read	Data Out	I _{DD}
L	H	X	L	Write	Data In	I _{DD}

DC CHARACTERISTICS

Absolute Maximum Ratings

PARAMETER	RATING	UNIT
Supply Voltage to V _{SS} Potential	-0.5 to +7.0	V
Input/Output to V _{SS} Potential	-0.5 to V _{DD} +0.5	V
Allowable Power Dissipation	1.0	W
Storage Temperature	-65 to +150	°C
Operating Temperature	0 to +70	°C

Note: Exposure to conditions beyond those listed under Absolute Maximum Ratings may adversely affect the life and reliability of the device.

Operating Characteristics

(V_{DD} = 5V ±10%, V_{SS} = 0V, T_A = 0 to 70° C)

PARAMETER	SYM.	TEST CONDITIONS	MIN.	TYP.	MAX.	UNIT	
Input Low Voltage	V _{IL}	-	-0.5	-	+0.8	V	
Input High Voltage	V _{IH}	-	+2.2	-	V _{DD} +0.5	V	
Input Leakage Current	I _{LI}	V _{IN} = V _{SS} to V _{DD}	-2	-	+2	μA	
Output Leakage Current	I _{LO}	V _{I/O} = V _{SS} to V _{DD} CS1 = V _{IH} (min.) or CS2 = V _{IL} (max.) or OE = V _{IH} (min.) or WE = V _{IL} (max.)	-2	-	+2	μA	
Output Low Voltage	V _{OL}	I _{OL} = +4.0 mA	-	-	0.4	V	
Output High Voltage	V _{OH}	I _{OH} = -1.0 mA	2.4	-	-	V	
Operating Power Supply Current	I _{DD}	CS1 = V _{IL} (max.), CS2 = V _{IH} (min.) I/O = 0 mA, Cycle = min. Duty = 100%	70	-	-	70	mA
			100	-	-	60	mA
Standby Power Supply Current	I _{SB}	CS1 = V _{IH} (min.) or CS2 = V _{IL} (max.), Cycle = min. Duty = 100%	-	-	3	mA	
	I _{SB1}	CS1 ≥ V _{DD} -0.2V or CS2 ≤ 0.2V	LL	-	-	20	μA
			L	-	-	50	μA

Note: Typical characteristics are at V_{DD} = 5 V, T_A = 25° C.



CAPACITANCE

(V_{DD} = 5V, T_A = 25° C, f = 1 MHz)

PARAMETER	SYM.	CONDITIONS	MAX.	UNIT
Input Capacitance	C _{IN}	V _{IN} = 0V	6	pF
Input/Output Capacitance	C _{I/O}	V _{OUT} = 0V	8	pF

Note: These parameters are sampled but not 100% tested.

AC CHARACTERISTICS

AC Test Conditions

PARAMETER	CONDITIONS
Input Pulse Levels	0.6V to 2.4V
Input Rise and Fall Times	5 nS
Input and Output Timing Reference Level	1.5V
Output Load	C _L = 100 pF, I _{OH} /I _{OL} = -1 mA/4 mA

AC Test Loads and Waveform

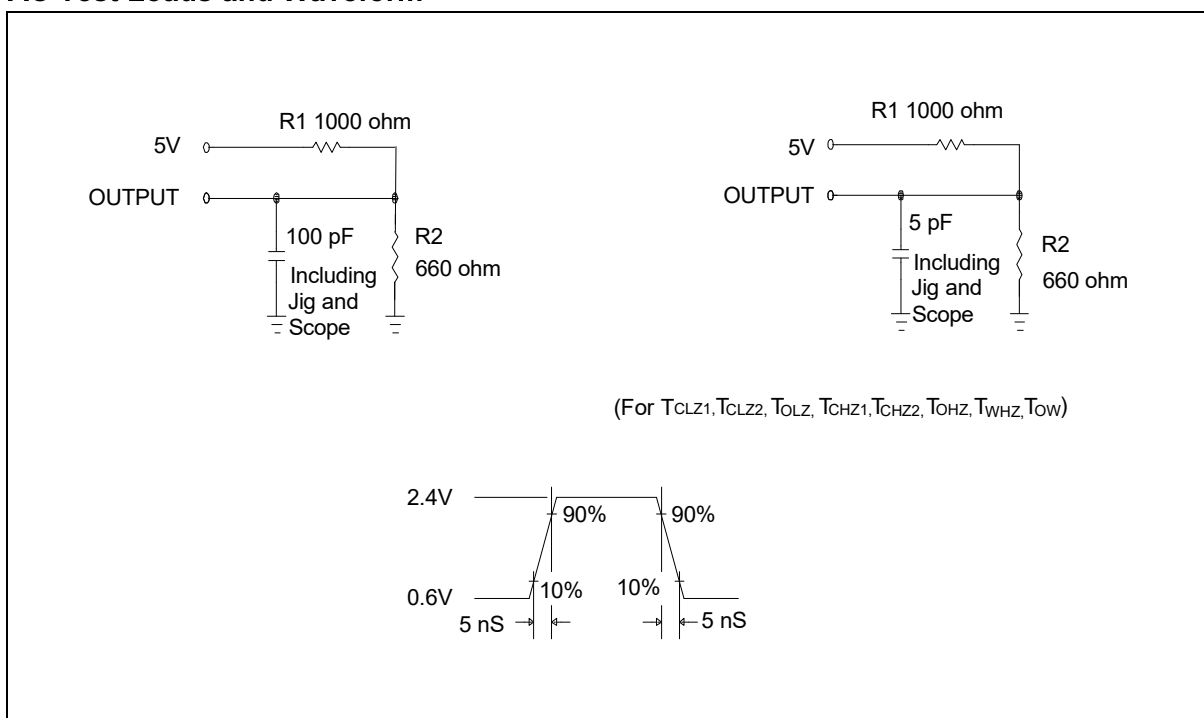



AC Characteristics, continued

(V_{DD} = 5V ±10%, V_{SS} = 0V, T_A = 0 to 70° C)**Read Cycle**

PARAMETER	SYM.	W2465-70		W2465-10		UNIT	
		MIN.	MAX.	MIN.	MAX.		
Read Cycle Time	TRC	70	-	100	-	nS	
Address Access Time	TAA	-	70	-	100	nS	
Chip Select Access Time	$\overline{\text{CS1}}$	TACS1	-	70	-	100	nS
	CS2	TACS2	-	70	-	100	nS
Output Enable to Output Valid	TAOE	-	35	-	50	nS	
Chip Selection to Output in Low Z	$\overline{\text{CS1}}$	TCLZ1*	5	-	10	-	nS
	CS2	TCLZ2*	5	-	10	-	nS
Output Enable to Output in Low Z	TOLZ*	5	-	5	-	nS	
Chip Deselection to Output in High Z	$\overline{\text{CS1}}$	TCHZ1*	-	30	-	35	nS
	CS2	TCHZ2*	-	30	-	35	nS
Output Disable to Output in High Z	TOHZ*	-	30	-	35	nS	
Output Hold from Address Change	TOH	10	-	10	-	nS	

* These parameters are sampled but not 100% tested.

Write Cycle

PARAMETER	SYM.	W2465-70		W2465-10		UNIT	
		MIN.	MAX.	MIN.	MAX.		
Write Cycle Time	TWC	70	-	100	-	nS	
Chip Selection to End of Write	$\overline{\text{CS1}}$	TCW1	60	-	80	-	nS
	CS2	TCW2	60	-	80	-	nS
Address Valid to End of Write	TAW	60	-	80	-	nS	
Address Setup Time	TAS	0	-	0	-	nS	
Write Pulse Width	TWP	45	-	60	-	nS	
Write Recovery Time	$\overline{\text{CS1}}, \overline{\text{WE}}$	TWR1	0	-	0	-	nS
	CS2	TWR2	0	-	0	-	nS
Data Valid to End of Write	TDW	30	-	40	-	nS	
Data Hold from End of Write	TDH	0	-	0	-	nS	
Write to Output in High Z	TWHZ*	-	30	-	30	nS	
Output Disable to Output in High Z	TOHZ*	-	30	-	30	nS	
Output Active from End of Write	TOW	0	-	0	-	nS	

* These parameters are sampled but not 100% tested.

TIMING WAVEFORMS

Read Cycle 1

(Address Controlled)

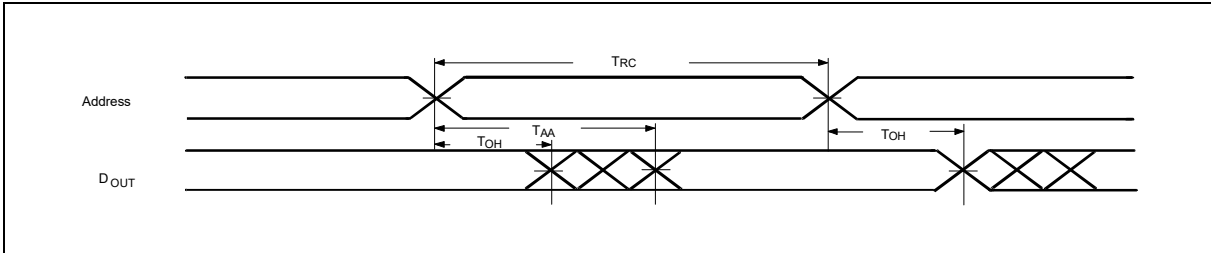

Read Cycle 2

(Chip Select Controlled)

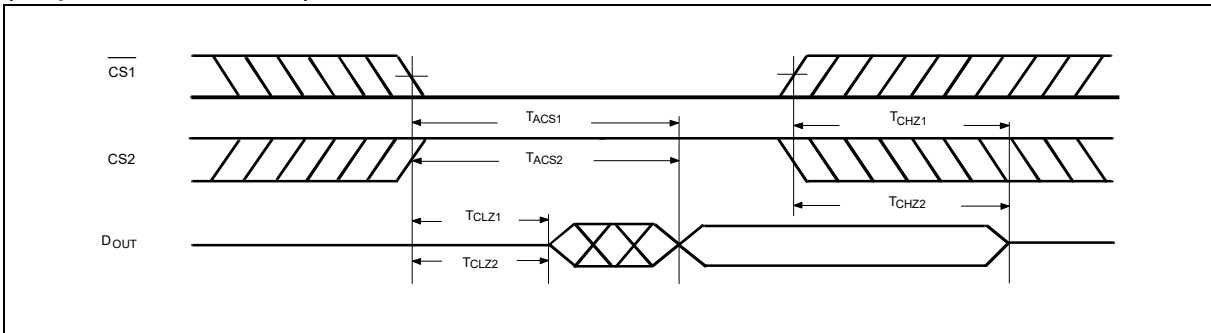

Read Cycle 3

(Output Enable Controlled)

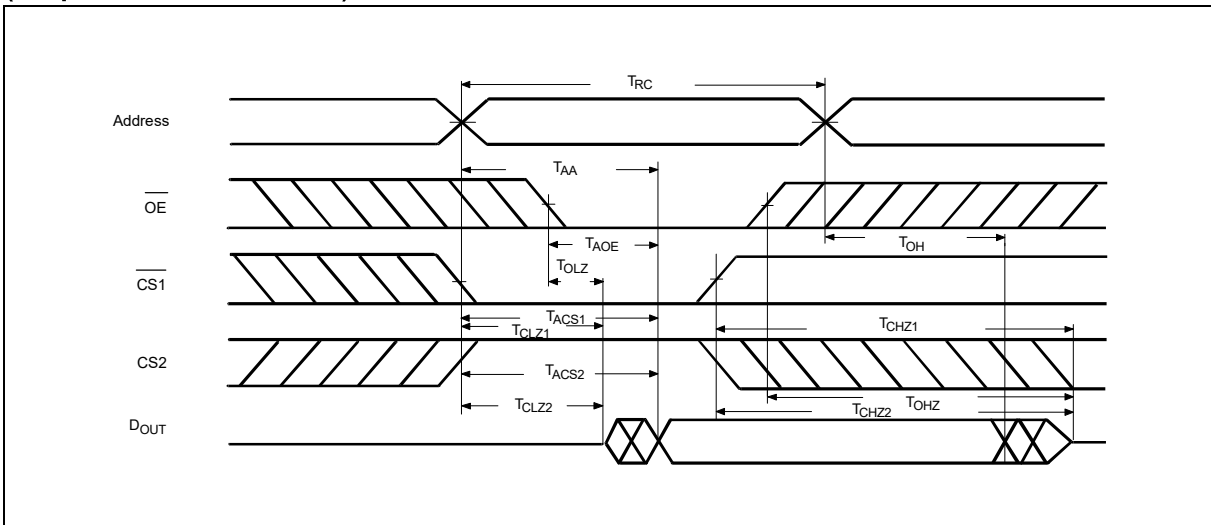

Timing Waveforms, continued

Write Cycle 1

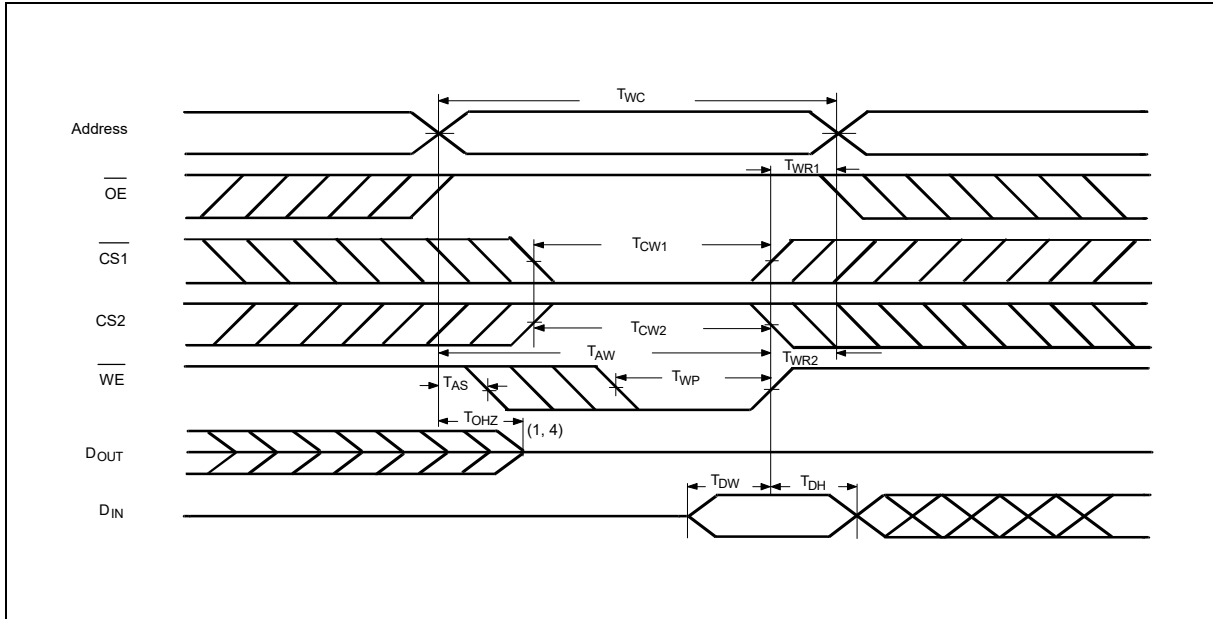

Write Cycle 2

($\overline{OE} = V_{IL}$ Fixed)

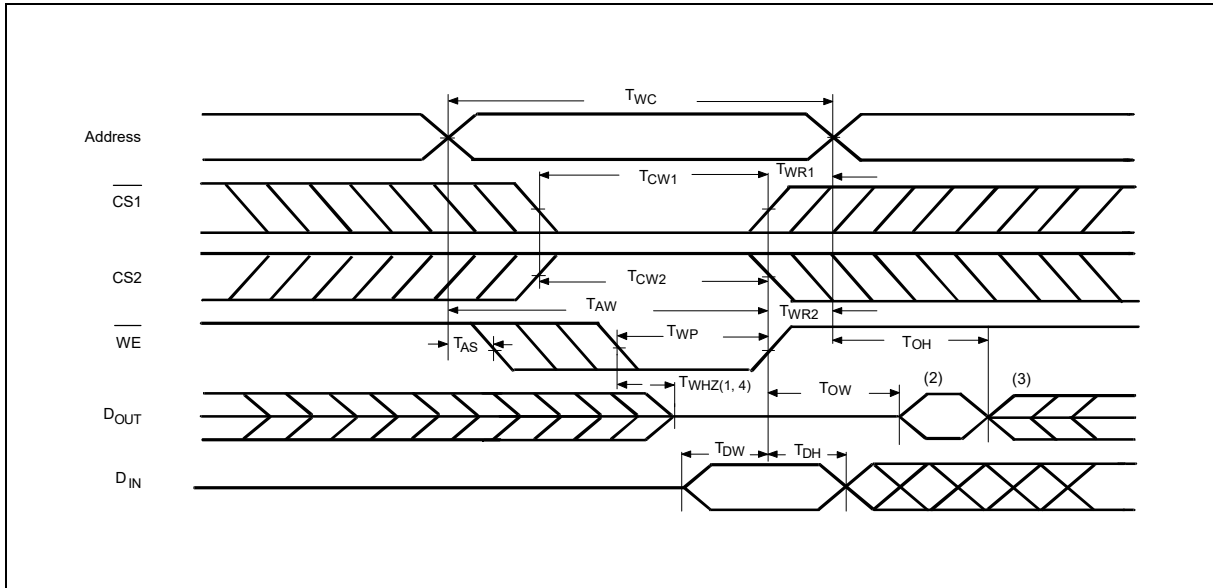

Notes:

1. During this period, I/O pins are in the output state, so input signals of opposite phase to the outputs should not be applied.
2. The data output from DOUT are the same as the data written to DIN during the write cycle.
3. DOUT provides the read data for the next address.
4. Transition is measured ± 500 mV from steady state with $C_L = 5$ pF. This parameter is guaranteed but not 100% tested.



DATA RETENTION CHARACTERISTICS

(TA = 0 to 70° C)

PARAMETER	SYM.	TEST CONDITIONS	MIN.	TYP.	MAX.	UNIT	
VDD for Data Retention	VDR	$\overline{CS1} \geq V_{DD} - 0.2V$, or $CS2 \leq 0.2V$	2.0	-	-	V	
Data Retention Current	IDDDR	$\overline{CS1} \geq V_{DD} - 0.2V$, or $CS2 \leq 0.2V$ $V_{DD} = 3V$	LL	-	-	10	μA
			L	-	-	20	μA
Chip Deselect to Data Retention Time	TCDR	See data retention waveforms	0	-	-	nS	
Operation Recovery Time	TR		TRC*	-	-	nS	

TRC* = Read Cycle Time

DATA RETENTION WAVEFORMS

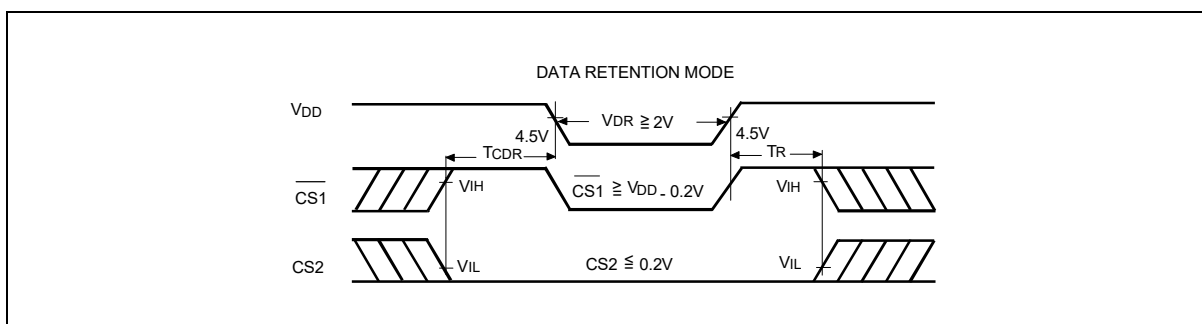

ORDERING INFORMATION

PART NO.	ACCESS TIME (nS)	OPERATING CURRENT MAX. (mA)	STANDBY CURRENT MAX. (μA)	PACKAGE
W2465-70LL	70	70	20	600 mil DIP
W2465-10L	100	60	50	600 mil DIP
W2465S-70LL	70	70	20	330 mil SOP
W2465S-10L	100	60	50	330 mil SOP
W2465K-70LL	70	70	20	300 mil Skinny
W2465K-10L	100	60	50	300 mil Skinny

Notes:

1. Winbond reserves the right to make changes to its products without prior notice.
2. Purchasers are responsible for performing appropriate quality assurance testing on products intended for use in applications where personal injury might occur as a consequence of product failure.

BONDING PAD DIAGRAM

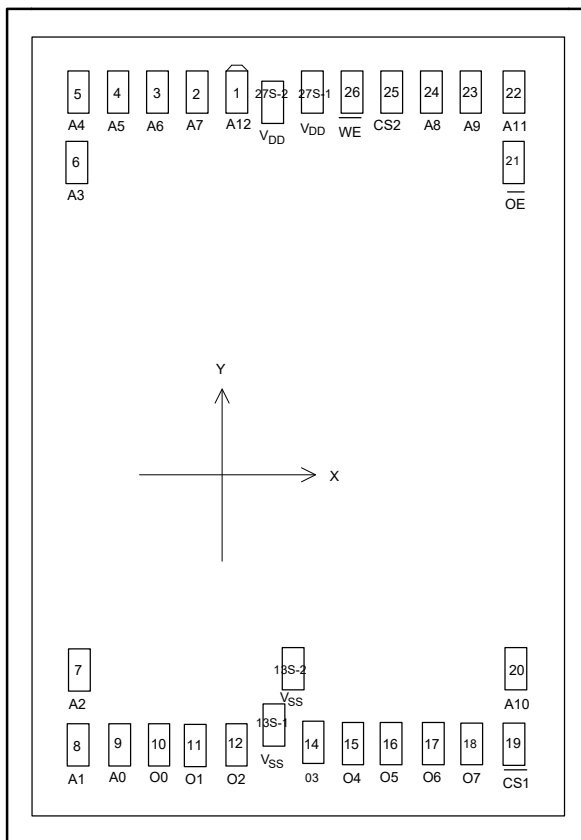

PAD NO.	X	Y
1	-226.95	1526.15
2	-350.95	1526.15
3	-484.10	1526.15
4	-608.10	1526.15
5	-739.75	1526.15
6	-741.75	1315.10
7	-741.75	-1231.85
8	-741.75	-1456.30
9	-610.60	-1456.30
10	-481.50	-1466.30
11	-343.80	-1466.30
12	-206.10	-1466.30
13S-1	-73.00	-1401.10
13S-2	-8.35	-1212.80
14	60.10	-1466.30
15	193.30	-1466.30
16	332.40	-1466.30
17	465.60	-1466.30
18	603.30	-1466.30
19	738.15	-1456.30
20	740.15	-1221.45
21	740.15	1310.80
22	738.15	1526.15
23	606.50	1526.15
24	482.50	1526.15
25	349.35	1526.15
26	225.35	1526.15
27S-1	94.20	1526.15
27S-2	-50.40	1456.10

Note: For bare chip form (C.O.B.) applications, the substrate must be connected to VDD or left floating in the PCB layout.

PACKAGE DIMENSIONS

28-pin P-DIP

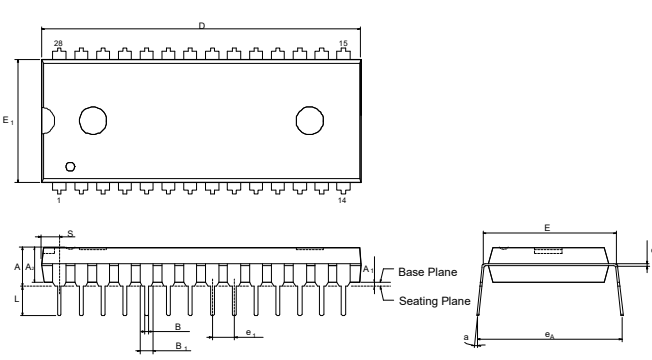

Symbol	Dimension in Inches			Dimension in mm		
	Min.	Nom.	Max.	Min.	Nom.	Max.
A	—	—	0.210	—	—	5.33
A ₁	0.010	—	—	0.25	—	—
A ₂	0.150	0.155	0.160	3.81	3.94	4.06
B	0.016	0.018	0.022	0.41	0.46	0.56
B ₁	0.058	0.060	0.064	1.47	1.52	1.63
C	0.008	0.010	0.014	0.20	0.25	0.36
D	—	1.460	1.470	—	37.08	37.34
E	0.590	0.600	0.610	14.99	15.24	15.49
E ₁	0.540	0.545	0.550	13.72	13.84	13.97
e ₁	0.090	0.100	0.110	2.29	2.54	2.79
L	0.120	0.130	0.140	3.05	3.30	3.56
a	0	—	15	0	—	15
e _A	0.630	0.650	0.670	16.00	16.51	17.02
S	—	—	0.090	—	—	2.29

Notes:
 1. Dimension D Max. & S include mold flash or tie bar burrs.
 2. Dimension E₁ does not include interlead flash.
 3. Dimension D & E₁ include mold mismatch and are determined at the mold parting line.
 4. Dimension B₁ does not include dambar protrusion/intrusion.
 5. Controlling dimension: Inches.
 6. General appearance spec. should be based on final visual inspection spec.

28-pin P-DIP Skinny

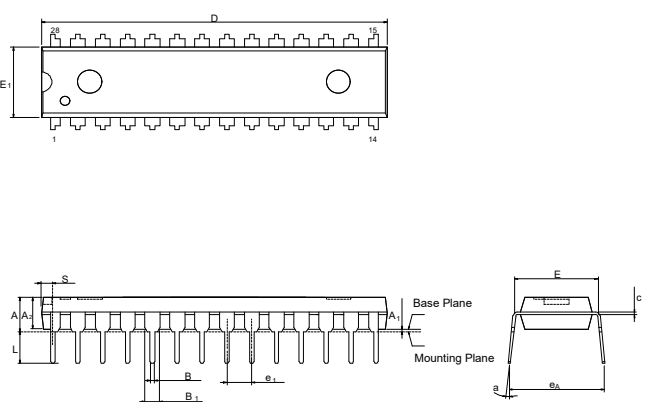

Symbol	Dimension in Inches			Dimension in mm		
	Min.	Nom.	Max.	Min.	Nom.	Max.
A	—	—	0.175	—	—	4.45
A ₁	0.010	—	—	0.25	—	—
A ₂	0.125	0.130	0.135	3.18	3.30	3.43
B	0.016	0.018	0.022	0.41	0.46	0.56
B ₁	0.058	0.060	0.064	1.47	1.52	1.63
C	0.008	0.010	0.014	0.20	0.25	0.36
D	—	1.388	1.400	—	35.26	35.56
E	0.300	0.310	0.320	7.62	7.87	8.13
E ₁	0.283	0.288	0.293	7.19	7.32	7.44
e ₁	0.090	0.100	0.110	2.29	2.54	2.79
L	0.120	0.130	0.140	3.05	3.30	3.56
a	0°	—	15°	0°	—	15°
e _A	0.330	0.350	0.370	8.38	8.89	9.40
S	—	—	0.055	—	—	1.40

Notes:
 1. Dimension D Max. & S include mold flash or tie bar burrs.
 2. Dimension E₁ does not include interlead flash.
 3. Dimension D & E₁ include mold mismatch and are determined at the mold parting line.
 4. Dimension B₁ does not include dambar protrusion/intrusion.
 5. Controlling dimension: Inches.
 6. General appearance spec. should be based on final visual inspection spec.



Package Dimensions, continued

28-pin SO Wide Body

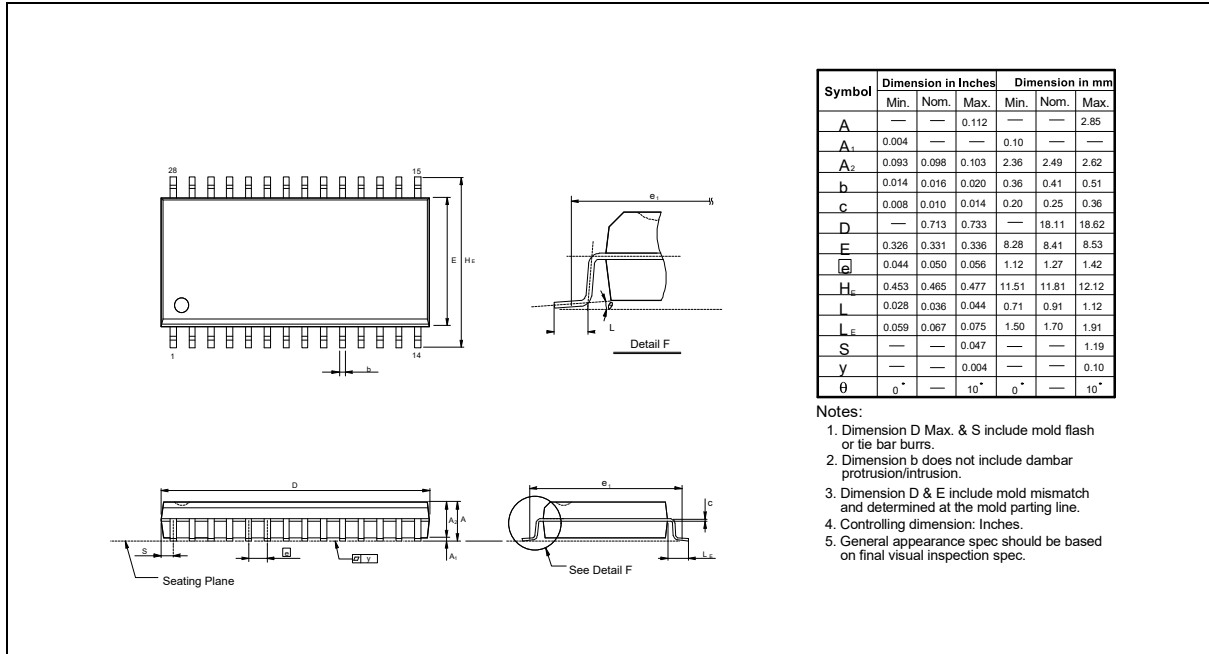

Headquarters
 No. 4, Creation Rd. III,
 Science-Based Industrial Park,
 Hsinchu, Taiwan
 TEL: 886-3-5770066
 FAX: 886-3-5792647
<http://www.winbond.com.tw/>
 Voice & Fax-on-demand: 886-2-7197006

Taipei Office
 11F, No. 115, Sec. 3, Min-Sheng East Rd.,
 Taipei, Taiwan
 TEL: 886-2-7190505
 FAX: 886-2-7197502

Winbond Electronics (H.K.) Ltd.
 Rm. 803, World Trade Square, Tower II,
 123 Hoi Bun Rd., Kwun Tong,
 Kowloon, Hong Kong
 TEL: 852-27513100
 FAX: 852-27552064

Winbond Electronics North America Corp.
Winbond Memory Lab.
Winbond Microelectronics Corp.
Winbond Systems Lab.
 2730 Orchard Parkway, San Jose,
 CA 95134, U.S.A.
 TEL: 1-408-9436666
 FAX: 1-408-9436668

Note: All data and specifications are subject to change without notice.